

VIKING PRODUCT MANUAL

SECURITY & COMMUNICATION SOLUTIONS

K-1700-IP Series

VoIP Entry Phone System
with Built-In Keypad

July 11, 2016

Vandal Resistant VoIP Entry Phone System with Integrated Keypad

The **K-1700-IP Series** entry phones provide a durable and attractive hands-free phone for apartment and residential door entry or applications requiring a vandal resistant VoIP speaker phone. The **K-1700-IP** phone is designed to provide quick and reliable hands-free communication for SIP VoIP phone systems with PoE. The unit can be programmed from any PC on the same LAN or remotely using a Static IP Address. The **K-1700-IP** entry phone can dial up to 250 programmable numbers and another 250 rollover numbers. They are available in two attractive finishes: "Brushed Stainless Steel" and "Oil Rubbed Bronze".

When the **K-1700-IP** phone is connected to an apartment or business tenant, a built-in contact closure may be activated to control an electric gate or door strike. Up to 1,000 keyless entry codes may be programmed, providing tenants with keyless entry. A 26 Bit Wiegand input is provided for adding an optional proximity card reader with capacity to program up to 1,000 card numbers. Keyless entry codes and card numbers can be programmed to only allow access at specific times and/or day of the week. The **K-1700-IP** includes a request for exit (REX) input and also offers activity logging.

⚠ Installation requires the assistance of a Network Administrator / IT Technician.



K-1700-IP
"Brushed 316 Stainless Steel"
(similar to brushed nickel)
(shown in optional surface mount box)



K-1700-BN-IP
"Oil Rubbed Bronze"
(satin dark brown powder paint
with fine copper metallic)

The **K-1700-IP-EWP** shares all of the features of the **K-1700-IP** in addition to Enhanced Weather Protection (EWP) for outdoor installations where the unit is exposed to precipitation or condensation. EWP products feature foam rubber gaskets and boots, sealed connections, gel-filled butt connectors, as well as urethane or thermal plastic potted circuit boards. For more information on EWP, see **DOD# 859**.

Features

- **Vandal Resistant Features:** 14 gauge louvered 316 stainless steel faceplate with permanent laser etched graphics. Speaker/mic screen. Heavy duty metal keypad and "Call" button. Scratch resistant powder coating (**K-1700-BN-IP**). T-10 Security Torx drive mounting screws.
- **Weather Resistant Features:** Marine grade 316 stainless steel faceplate, screws and push button switch. Switch internally sealed per IP67. Mylar speaker. Self-draining mic mount. Faceplate, mic and speaker gaskets. Weather resistant powder paint (**K-1700-BN-IP**)
- Available in 2 standard finishes: 316 brushed stainless steel with laser etched graphics or oil rubbed bronze powder paint with copper metallic graphics
- Two sets of SPDT 2 Amp relay contacts for door/gate or camera control
- Optional **RC-4A** for Secure Remote Relay Control, see **DOD# 582**
- Blue "Call /Status" LED indicator
- SIP compliant (see pg 2 for list of compatible IP-PBX phone systems)
- PoE powered (class 2, <6.5 watts)
- Automatic Noise Canceling (ANC) feature for operation in noisy environments
- Viking's proprietary VOX switching eliminates the need for "Push to Talk" mode
- Network downloadable firmware
- 26 Bit Wiegand input for optional proximity card readers, see **DOD# 221 & 228**
- Programmable to speed dial up to 250 numbers
- Cycles to roll over phone number on busy or no-answer
- Program up to 1,000 keyless entry codes and/or proximity card numbers
- Keyless entry codes and proximity card numbers can be programmed to only allow access at specific times and day of week
- Event logging with time and date stamp
- Optional Enhanced Weather Protection (EWP), EWP products are designed to meet IP66 Ingress Protection Rating, see **DOD# 859**
- Hangs up on busy signal, time-out or touch tone command
- Remotely programmable
- Extended temperature range (-40°F to 140°F)
- Programmable volume adjustments for microphone and speaker
- Selectable auto-answer feature for monitoring
- Zinc plated steel rough-in box included
- Optional **VE-6x7** Surface Mount Box available, see **DOD #424**
- Optional **VE-LIGHT** kit to illuminate the front panel at night, see **DOD# 428**
- Self diagnostics (testing: com, mic, speaker, and switch)

Applications

- Apartment Entry Phone
- Residential Gate Entrance
- Door Entry Phone
- Courtesy Assistance Phone
- Customer Service Phone
- Automated Teller (ATM) Phone
- Security or Emergency Phone
- Hot-Line Phone
- Kiosk Phone with up to 250 number speed dialing

Information: 715-386-8861
www.vikingelectronics.com

Specifications

Power: PoE class 2 (<6.5 watts)
Dimensions: Overall: 5.5" x 6.5" x 2.6" (140mm x 165mm x 66mm)
 Rough-in box: 4.5" x 5.5" x 2.5" (114mm x 140mm x 64mm)
Shipping Weight: 1.5 kg (3.2 lbs)
Operating Temperature: -40°F to 140°F (-40° C to 60° C)
Humidity - Standard Products: 5% to 95% non-condensing
Humidity - EWP Products: Up to 100%
Audio Codecs: G711u, G711a, G722
Network Compliance: IEEE 802.3 af PoE, SIP 2.0 RFC3261, 100BASE-TX with auto cross over
Connections: (1) RJ45 10/100 Base-T, (14) gel-filled butt connectors

Viking VoIP SIP System Compatibility List

NOTE: Exclusion from this list means only that compatibility has not been verified, it does not mean incompatibility.

For detailed configuration instructions for certain vendors below, see **Configuring Viking VoIP Phone and SIP Servers, DOD# 944**.

Vendor	Infrastructure Class				
	Softswitch	PBX	Proxy	SBC (session border controller)	Service Provider
3COM VCX		X			
3CX		X			
Aastra		X			
Asterisk		X			
Atcom		X			
Avaya Aura Communication Manager	X				
Avaya IP Office		X			
BlueBox		X			
Brekeke		X			
Callcentric					X
Cisco Unified Communications Manager (CUCM)	X	X			
Cisco Unified Communications Manager Express (CUCME)	X	X			
Elastix		X			
Freeswitch		X			
Grandstream		X			
Interactive Intelligence	X	X			
iptel.org					X
Kamailio			X	X	
MetaSwitch				X	X
NEC		X			
OfficeSIP		X			
OpenSIPS		X			
Panasonic** (with SIP Extension Card)		X			
Samsung Communications Manager (SCM)	X	X			
ShoreTel*		X			
Siemens Communications Server (SCS)		X			
SIP Express Router (SER)			X	X	
sip.antisip.com					X
Snom PBX		X			
Sonus				X	
Switchvox		X			X
Teksip			X		
Toshiba		X			
VoIP.ms					X

* **Note:** Not compatible with ShoreTel Ring Group/Hunt Group (unit can be programmed to ring an extension 2 or 3 times then roll to the next number, for a total of 5 numbers).

** **Note:** Relay operation commands are Not compatible with Panasonic Phone Systems (Panasonic does not transmit DTMF between station ports).

Known Incompatible System or Service Provider: Ring Central (Requires Authorization ID and Proxy address).

Definitions

Client: A computer or device that makes use of a server. As an example, the client might request a particular file from the server.

DHCP: Dynamic Host Configuration Protocol. In this procedure the network server or router takes note of a client's MAC address and assigns an IP address to allow the client to communicate with other devices on the network.

DNS Server: A DNS (Domain Name System) server translates domain names (ie: www.vikingelectronics.com) into an IP address.

Ethernet: Ethernet is the most commonly used LAN technology. An Ethernet Local Area Network typically uses twisted pair wires to achieve transmission speeds up to 1Gbps.

Host: A computer or device connected to a network.

Host Name: A host name is a label assigned to a device connected to a computer network that is used to identify the device in various forms of network communication.

Hosts File: A file stored in a computer that lists host names and their corresponding IP addresses with the purpose of mapping addresses to hosts or vice versa.

Internet: A worldwide system of computer networks running on IP protocol which can be accessed by individual computers or networks.

IP: Internet Protocol is the set of communications conventions that govern the way computers communicate on networks and on the Internet.

IP Address: This is the address that uniquely identifies a host on a network.

LAN: Local Area Network. A LAN is a network connecting computers and other devices within an office or building.

Lease: The amount of time a DHCP server reserves an address it has assigned. If the address isn't used by the host for a period of time, the lease can expire and the address can be assigned to another host.

MAC Address: MAC stands for Media Access Control. A MAC address, also called a hardware address or physical address, is a unique address assigned to a device at the factory. It resides in the device's memory and is used by routers to send network traffic to the correct IP address. You can find the MAC address of your **K-1700-IP** phone printed on a white label on the top surface of the PoE LAN port.

Router: A device that forwards data from one network to another. In order to send information to the right location, routers look at IP Address, MAC Address and Subnet Mask.

RTP: Real-Time Transport Protocol is an Internet protocol standard that specifies a way for programs to manage the real-time transmission of multimedia data over either unicast or multicast network services.

Server: A computer or device that fulfills requests from a client. This could involve the server sending a particular file requested by the client.

Session Initiation Protocol (SIP): Is a signaling communications protocol, widely used for controlling multimedia communication sessions such as voice and video calls over Internet Protocol (IP) networks. The protocol defines the messages that are sent between endpoints, which govern establishment, termination and other essential elements of a call.

Static IP Address: A static IP Address has been assigned manually and is permanent until it is manually removed. It is not subject to the Lease limitations of a Dynamic IP Address assigned by the DHCP Server. The default static IP Address is: **192.168.154.1**

Subnet: A portion of a network that shares a common address component. On TCP/IP networks, subnets are defined as all devices whose IP addresses have the same prefix. For example, all devices with IP addresses that start with 100.100.100. would be part of the same subnet. Dividing a network into subnets is useful for both security and performance reasons. IP networks are divided using a subnet mask.

TCP/IP: Transmission Control Protocol/Internet Protocol is the suite of communications protocols used to connect hosts on the Internet. TCP/IP uses several protocols, the two main ones being TCP and IP. TCP/IP is built into the UNIX operating system and is used by the Internet, making it the de facto standard for transmitting data over networks.

TISP: Telephone Internet Service Provider

WAN: Wide Area Network. A WAN is a network comprising a large geographical area like a state or country. The largest WAN is the Internet.

Wireless Access Point (AP): A device that allows wireless devices to connect to a wired network using Wi-Fi, or related standards. The AP usually connects to a router (via a wired network) as a standalone device, but it can also be an integral component of the router itself.

Wireless Repeater (Wireless Range Extender): takes an existing signal from a wireless router or access point and rebroadcasts it to create a second network. When two or more hosts have to be connected with one another over the IEEE 802.11 protocol and the distance is too long for a direct connection to be established, a wireless repeater is used to bridge the gap.

Features Overview

Front View of the K-1700-IP Entry Phone

Mounting Screws: (4) 6-32 X 3/4" Marine grade 316 stainless steel, flat head, T-10 Torx security screws and drive bit (included).

Faceplate Material: 14 gauge 316 stainless steel. The SS model has a #4 brushed finish, the BN model has a powder painted finish.

Blue Call LED: Lights steady to help locate the button in low light, flashes during dialing, then lights steady when answered.

Condensation Drain Hole

Laser Etched Graphics: For long lasting easy to read graphics. Copper metallic on "oil rubbed bronze" model K-1700-BN-IP.

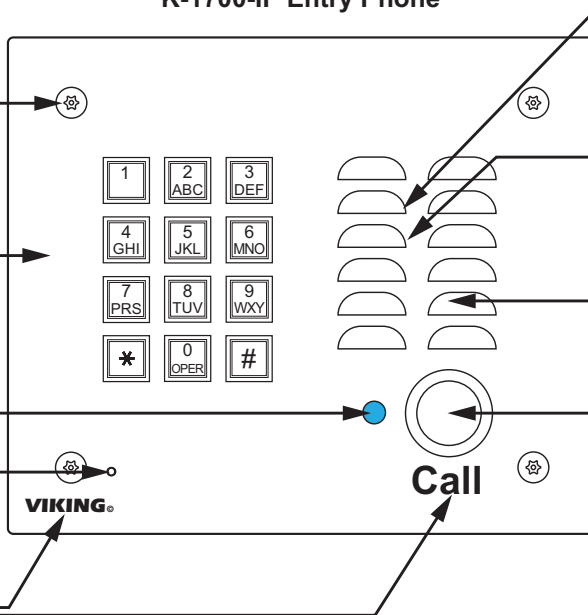

Speaker: Mylar speaker with rubber gasket to maintain water-tight seal and eliminate water deterioration.

Speaker Screen: Speaker screen with 0.018" wide slots to prevent punctures from paperclips, etc.

Microphone: Omni-directional microphone with protective water-resistant cloth.

Push Button Switch: Push to initiate call, push again to disconnect. Solid 316 stainless steel, internally sealed per IP67.

Rear (PCB) View of the K-1700-IP Entry Phone

Model PRX-1
Proximity Card Reader DOD# 221



Model PRX-3 Medium Range Proximity Card Reader DOD# 228



26 Bit Wiegand Input

For connecting optional Proximity Card Readers, see Viking models above (not included)

- White
- Green
- + Red
- Black

12 VDC Power Output for VE-LIGHT, etc. (12VDC @ 50mA max)

- Black
- + Red

Request for Exit (REX) Input

- Green
- Green

Relay 2 Output Contacts (2A@30VDC/ 250VAC max)

- N.C. Brown
- COM. Violet
- N.O. White

Connect to Optional Doorstrike, Mag Lock, Gate Controller, etc.

Relay 1 Output Contacts (2A@30VDC/ 250VAC max)

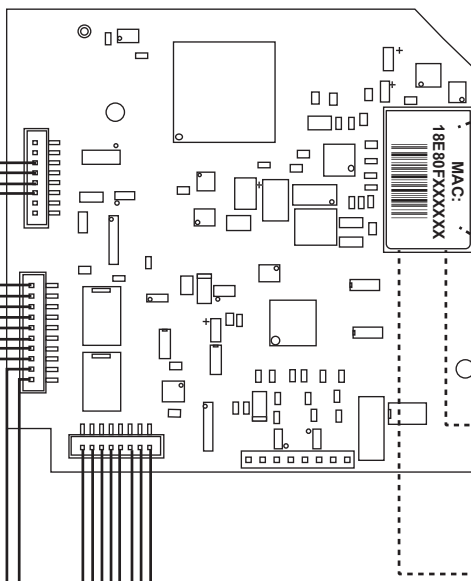
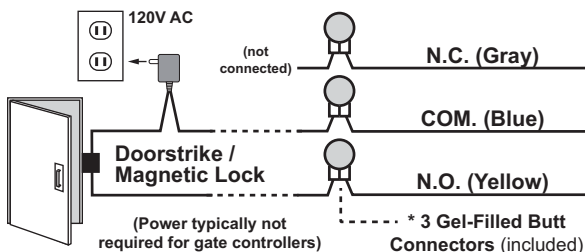

PoE LAN Port 10/100, PoE Class 2 (<6.5 Watts): Connect to your LAN via RJ45 plug and CAT5 or greater twisted pair wire.

MAC Address Label: The MAC address is a unique 12 digit number used by routers to send network traffic to the correct IP address.

Yellow Network Status LED: Lights steady to indicate power and data link. Blinks to indicate network activity.

Green Unit Status LED

- White Speaker
- White Speaker
- + Red LED
- Black LED
- Black Microphone
- + Red Microphone
- Black Call Switch
- Black Call Switch

* **Note:** The gel-filled (water-tight) butt connectors are designed for insulation displacement on 19-26 gauge wire with a maximum insulation of 0.082 inches.

Installation and Mounting

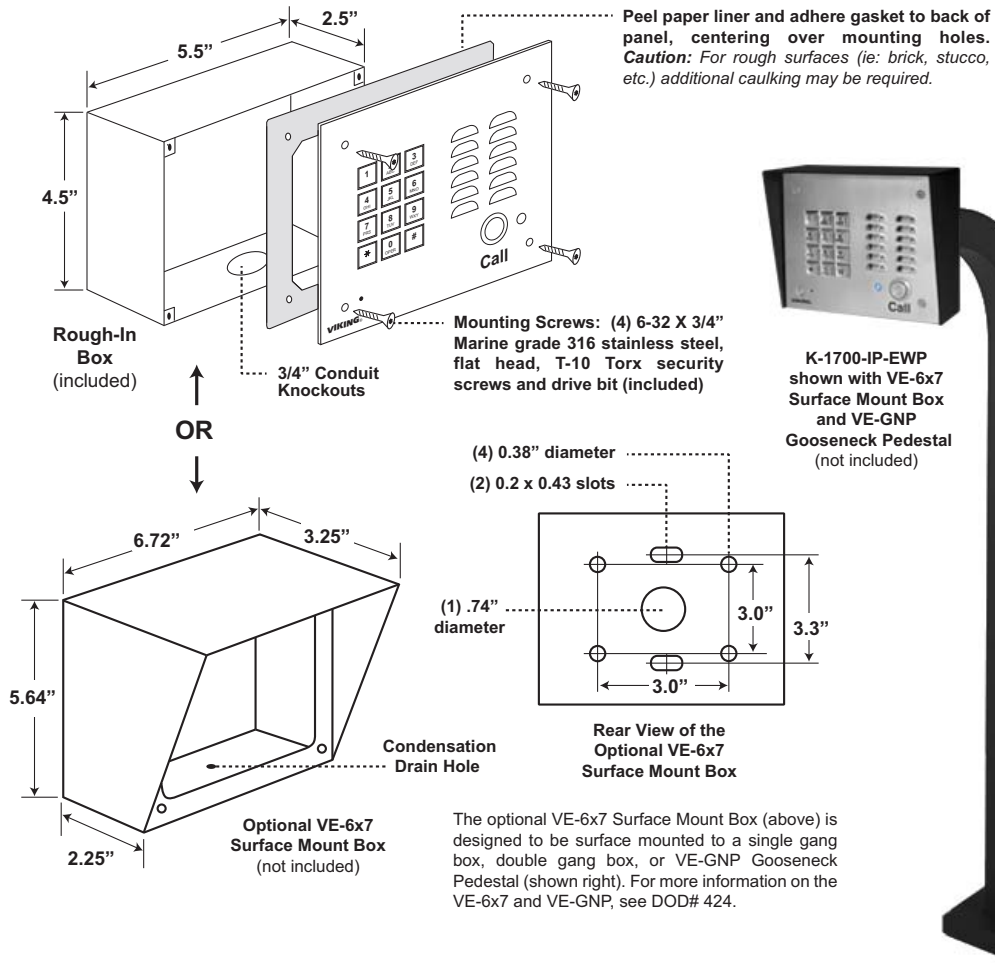

Applications / Wiring

A. Adding a Viking Model PRX-3 Medium Range Proximity Card Reader

! IMPORTANT: Electronic devices are susceptible to lightning and power station electrical surges from both the AC outlet and the telephone line. It is recommended that a surge protector be installed to protect against such surges.

When mounting a **PRX-3** in close proximity of the **K-1700-IP** (I.E. using a **PRX-3-MK-GNP** mounting Kit) In programming set "Relay 2 mode" to "Alarm" and wire as shown below. For more Information on **PRX-3** See DOD# 228.

When using the **PRX-3** with any Viking Entry System/Controller, the provided 12V DC 500mA power adapter and 2200µF bi polar capacitor should be used.

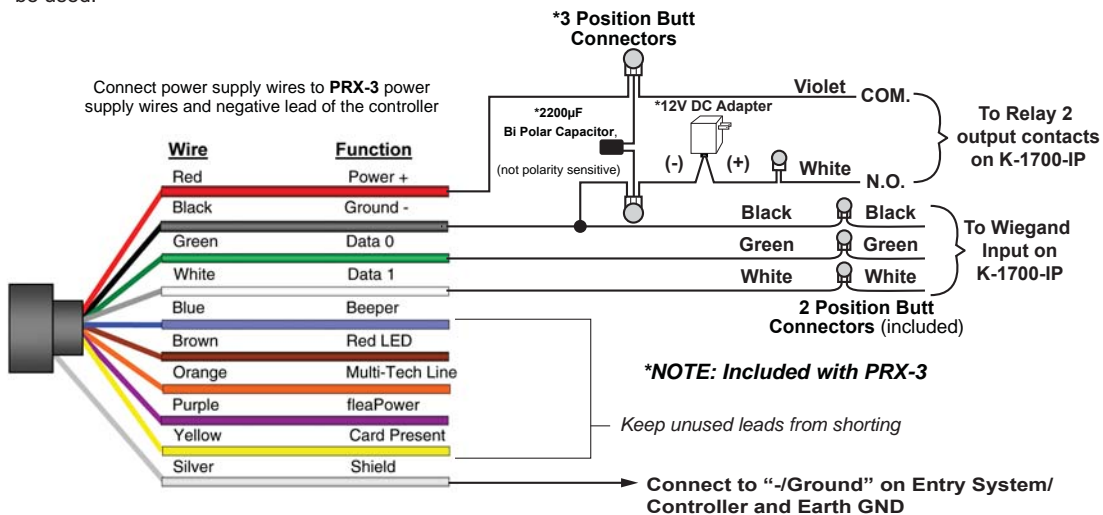

B. Using a Viking Model RC-4A For Secure Remote Relay Control

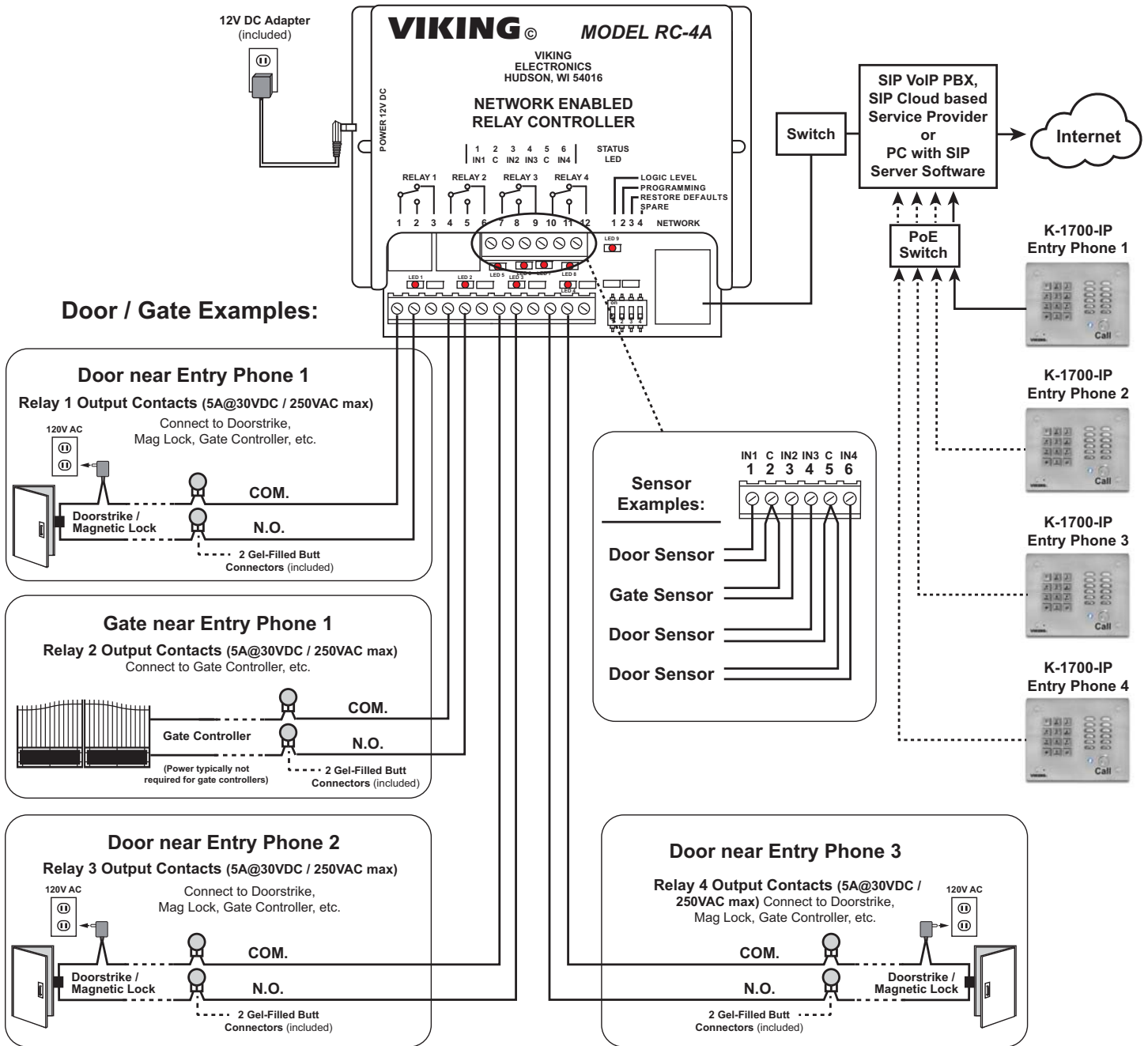

The front panel of the **K-1700-IP** is mounted using security Torx screws to help prevent intruders from removing the panel and accessing the on board door strike/gate control relays. For applications requiring additional security, a Viking model **RC-4A** remote relay controller can be used. The relay controller is mounted securely inside the building and connected to the same LAN as the **K-1700-IP**. The on board door strike relays would not be used in this case as the **K-1700-IP** will send an encrypted message to the **RC-4A** to activate its relays which control the door strikes/gates.

Up to 4 **K-1700-IP**'s can communicate with one **RC-4A** allowing you to securely control four entrances.

When using an **RC-4A** for remote relay control the **K-1700-IP**'s relays should be set to "External" in the PC programming.

Note: If the **K-1700-IP** loses communications with the **RC-4A**, the LED on the front panel of the **K-1700-IP** will flash 3 times every 2 seconds indicating the communication error. If this error occurs, make sure the **RC-4A** is powered, has a network connection and has the correct IP address and security code of the **K-1700-IP** displaying errors.

Typical Installation on SIP Based VoIP Phone System

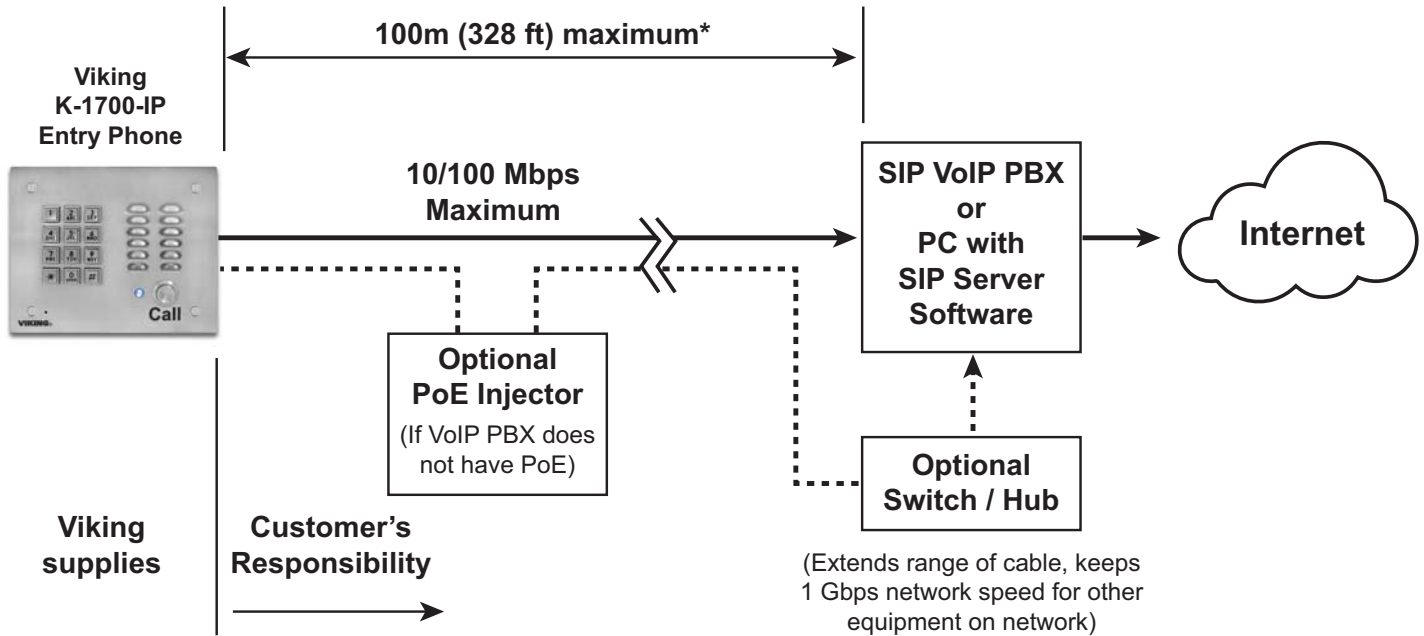

* **Note:** A PoE extender can be used for an additional 100 meters per extender. For longer runs (up to 2 km / 1.2 miles) a ethernet to fiber media converter can be used.

PC Requirements

- **IBM** compatible personal computer with:
 - Windows 2000 (service pack 4 or higher)
 - Windows XP (service pack 2 or higher)
 - Windows Vista (SP2 or newer), 32 or 64 bit versions
 - Windows 7
 - Windows 8
 - Windows 10
- Adobe Acrobat Reader 8 or higher
- **K-1700-IP** hardware
- Available LAN with PoE (class 2, <6.5 watts)
- Ethernet cable (CAT5 min.)
- 1 MB minimum free hard drive space for installation
- 16MB of free physical RAM

PC Programming

A DVD is included with each **K-1700-IP** VoIP Entry Phone. The DVD contains the application "**K-1700-IP Tech Tool**" used to program the unit using a PC running Windows 2000, XP, Vista, Windows 7, Windows 8 or Windows 10 (see System Requirements above). The PC must be connected to the same LAN as the **K-1700-IP** VoIP phone. Install the application on your PC by placing the DVD into your PC's drive. Click "I Accept" on the bottom of the first screen, then select "Viking K-1700-IP Tech Tool" and click the "Install" button. Follow the directions on the screen. To start the Viking K-1700-IP Tech Tool application, click on the Viking K-1700-IP Tech Tool icon on your desk top. The Main screen will appear, allowing the user to program any **K-1700-IP** phone connected to that LAN.

A. Manually Muting SIP/Network Failure Alarm Beeps (3 beeps repeated every 30 seconds)

With the unit connected and powered (Green LED on and Yellow LED off or blinking) it will output 3 beeps every 30 seconds and turn the Call/Call Connected LED on and off once per second to indicate a SIP registration failure, failure to receive an echo reply from pinged gateway or Ethernet connection failure. You can manually disable the beeps by pressing and holding the Call button for 5 seconds (2 beeps will then be heard) or by clicking the "Mute Alarm Until Next Failure" button in the Viking VoIP programming software. The LED will continue to flash allowing you to trouble shoot the failure.

B. Configuring the K-1700-IP Network Settings

Step 1.	Open the “Viking K-1700-IP Phone Programming” software on a windows PC that is connected to the same LAN as the K-1700-IP phone to be programmed.
Step 2.	The window in the upper left corner of the menu will show you each K-1700-IP phone that is connected to that LAN. Select the unit with the same MAC address shown on the label located on the top of the Ethernet connector on the K-1700-IP phone.
Step 3.	Click the “Connect” button. If a pop up window appears, enter the unit’s security code (factory set to 845464) then click “OK”.
Step 4.	The program will then read and display the K-1700-IP phone’s IP and programming settings.
Step 5.	After adjusting the IP and phones settings, click the “Write” button under each column of settings to send the programming commands to the connected unit.

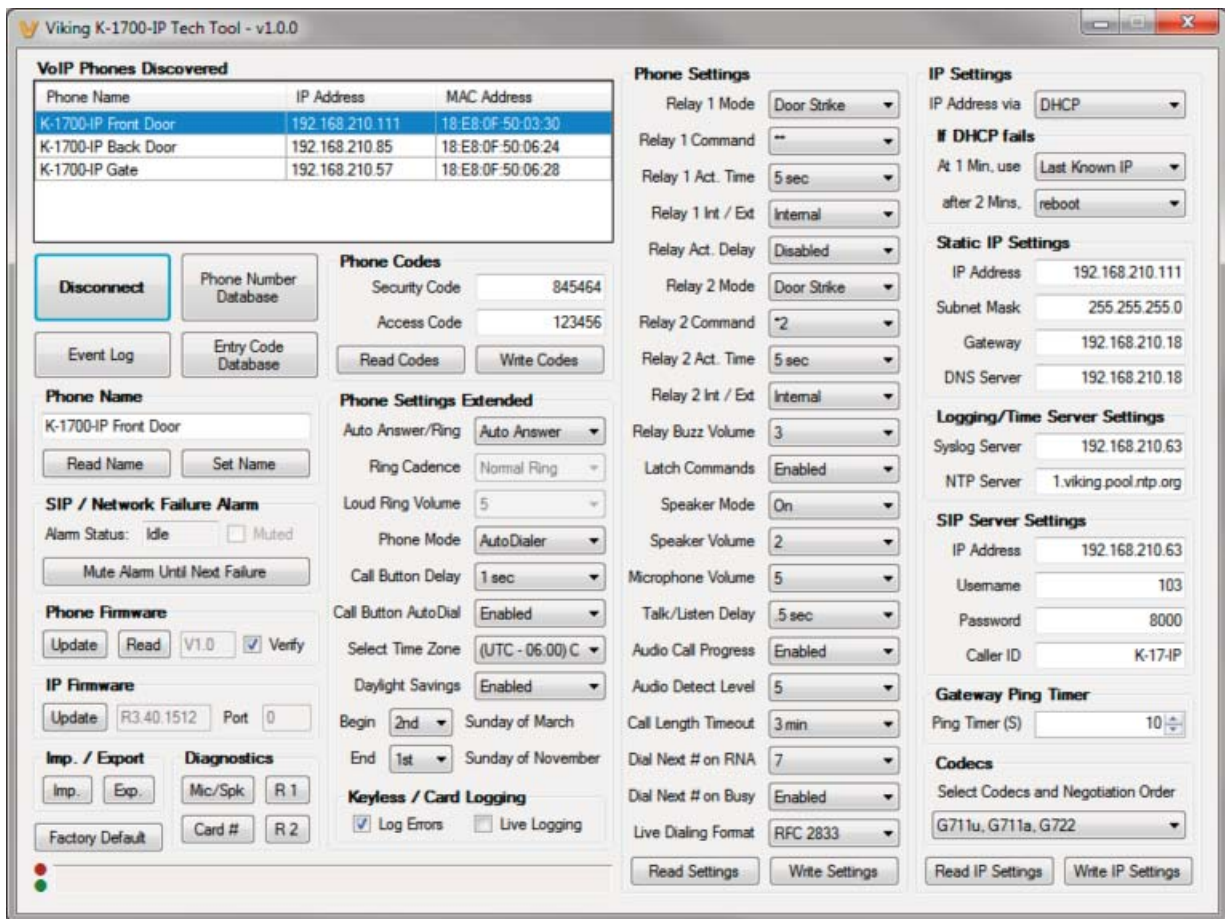

C. Manually Resetting the Security Code to Factory Default

Step 1.	Power down the phone by disconnecting the RJ45 plug.
Step 2.	Press and hold the CALL button, then reconnect the RJ45.
Step 3.	Continue to hold the button until you hear 2 beeps, (approximately 6 seconds). Then release the button. The “Call Connected” LED will remain off for the first 3 seconds, flash slowly for 3 seconds then fast flash (after 2 beeps) indicating when to release button.
Step 4.	The security code is now reset to 845464 (factory default).
Step 5.	You can now enter programming by following the steps in section B above.

D. Manually Resetting All Network Parameters to Factory Default

Step 1.	Power down the K-1700-IP phone by disconnecting the RJ45 plug.
Step 2.	Press and hold the CALL button, then reconnect the RJ45.
Step 3.	Continue to hold the button until you hear 2 beeps, (approximately 6 seconds). Continue to hold the button until you hear 4 more beeps, approximately 6 seconds later, then release the button. The “Call” LED will remain off for the first 3 seconds, flash slowly for 3 seconds (2 beeps), fast flash for 6 seconds (4 beeps), then light steady indicating when to release button.
Step 4.	The unit should continue to output double beeps and slowly flash the LED indicating all Network Parameters are now reset to factory default.
Step 5.	You will be required to re-enter your initial network settings, see section B above.

Programming Features Index

DESCRIPTION	Section	Page
Connect/Disconnect	1	10
Phone Number Database	2	11
Event Log	3	12
Entry Code Database	4	13
Phone Name	5	13
Mute Alarm Until Next Failure	6	13
Phone Firmware	7	13
IP Firmware	8	13
Import/Export	9	14
Factory Default	10	14
Diagnostics (used to check mic, speaker, relays and proximity card reader operation)	11	14
Security code (factory set to 845464)	12	14
Access Code (1-6 digits, blank = disabled, factory set to 123456)	13	14
Auto Answer / Loud Ring (Disabled, Auto Answer, Loud Ring, Loud Ring with AGC, factory set to Auto Answer)	14	14
Ring Cadence (factory Set to Normal Ring)	15	14
Loud Ring Volume (0-9, 1 - low, 9 - high, 0 = disabled, factory set to 5)	16	14
Phone Mode (Auto Dialer or Manual Dial Phone, factory Set to Auto Dialer)	17	15
Call Button Delay	18	15
Call Button Auto Dial	19	15
Select Time Zone	20	15
Daylight Savings	21	15
Keyless/Card Logging	22	15
Relay 1 or 2 Mode (Door Strike, Outbound Call, In/Outbound Call, Doorbell, Alarm Mode, factory set to Door Strike)	23	16
Relay 1 or 2 Command (1 or 2 digits, factory set to ** and *2) (Relay Mode must be set to Door Strike)	24	16
Relay 1 or 2 Time (0.5 - 99 sec, factory set to 5 sec)	25	16
Relay 1 or 2 Int/Ext (factory set to Internal)	26	16
Relay Act. Delay (Disabled or 0.5 - 99 sec, factory set to Disabled)	27	16
Relay Buzz (Activation Tone) Volume (1 digit 0-3, 0 = off, factory set to 3)	28	17
Latch Commands (Enabled or Disabled, factory set to Enabled)	29	17
Speaker Mode (OFF/Silent Monitor or ON, factory set to ON)	30	17
Speaker Volume (0-9, factory set to 2)	31	17
Microphone Volume (0-9, 0 = ANC, factory set to 5)	32	17
Talk/Listen Delay (VOX) (.1 to .9 sec, factory set to .5 sec)	33	17
Audio Call Progress (OFF, ON, factory set to ON)	34	17
Audio Detect Level (1-9, 1 = min, 9 = max, factory set to 5, power cycle unit after setting)	35	17
Call Length Time Out (disabled or 1 to 9 min, factory set to 3 min)	36	18
Dial Next # on RNA (Ring No Answer) (disabled, 1 - 9 = number of rings, factory set to 7)	37	18
Dial Next # on Busy (disabled or enabled, factory set to enabled)	38	18
Live Dialing Format (Inband DTMF or RFC2833, factory set to RFC2833)	39	18
REX Input	40	18

Programming Features

1. Connect/Disconnect

To connect to a **K-1700-IP** shown in the upper left VoIP Phones Discovered window, simply click the unit then click the “Connect” button. The preprogrammed settings should then fill the tech tool window. When you are finished writing the programming changes, the disconnect button allows you to disconnect from the unit you have finished programming and connect to the next unit. Closing the PC programming will also automatically disconnect the unit.

The screenshot displays the Viking K-1700-IP Tech Tool - v1.0.0 interface. It features several panels for configuration:

- VoIP Phones Discovered:** A table listing discovered units with columns for Phone Name, IP Address, and MAC Address. The first unit, K-1700-IP Front Door, is selected.
- Phone Settings:** A central panel with numerous dropdown menus and buttons for configuring Relay 1 and 2 modes, commands, act. times, and delays. It also includes settings for speaker mode, volume, and microphone.
- IP Settings:** A panel on the right for configuring network settings, including IP Address via DHCP, static IP settings, and logging/time server settings.
- Phone Codes:** A section for setting Security Code (845464) and Access Code (123456), with buttons for Read Codes and Write Codes.
- Phone Settings Extended:** A section for configuring Auto Answer/Ring, Ring Cadence, Loud Ring Volume, Phone Mode (AutoDialer), Call Button Delay, and Select Time Zone.
- Phone Firmware:** A section for updating and verifying the phone's firmware (V1.0).
- IP Firmware:** A section for updating the IP firmware (R3.40.1512) and setting the port (0).
- Imp. / Export and Diagnostics:** Buttons for importing/exporting settings and running diagnostics (Mic/Spk, R1, Card #, R2).
- Keyless / Card Logging:** A section with checkboxes for Log Errors and Live Logging.

At the bottom, there are buttons for Read Settings, Write Settings, Read IP Settings, and Write IP Settings. A status bar at the very bottom shows a red light and a green light.

2. Phone Number Database

Clicking on the “Phone Number Database” button will open a screen allowing you to program all the Tenants Name’s, Speed Dial Numbers, and Primary and Roll Over phone numbers. Tenant names are stored locally on the PC and are not uploaded.

The Speed Dial Number is the 1 to 3 digit number visitors enter on the **K-1700-IP**’s keypad for the unit to call the tenant. 3 seconds after the 1 to 3 digit number is entered, the unit will then dial the Primary Phone Number associated with that Speed Dial Number. If there is no answer or a busy signal is detected, the **K-1700-IP** will then dial the Roll Over Phone Number.

The Primary Phone Number programmed in Index 0 is the number that is dialed when the “CALL” button is pressed with no additional digits (if “Call Button Autodial” is enabled). A second Roll Over Number will be dialed when there is no answer or a busy signal is detected. The **K-1700-IP** phone is factory set with no Primary or Roll Over numbers programmed.

Note: Typical Apartment Applications use the tenant’s 1 to 3 digit apartment number as the Speed Dial Number. After the apartment number is entered the unit will then dial the tenant’s phone number.

The screenshot shows the 'Phone Number Database' window in the Viking K-1700-IP Tech Tool. The window contains a table with the following data:

Index	Tenant Name	Speed Dial	Primary Phone Number	Roll Over Phone Number
0	Bob Jones (Building Manager)	0	5550001	6125554321
1	Jim and Marge Thompson (Apt 101)	101	5550101	7155559876
2	Bruce Springfield (Apt 102)	102	5550102	6515556666
3	Frank Thistlewight (Apt 103)	103	5550103	
4	George Parker (Apt 104)	104	5550104	7155551346
5				
6	Maggie Thompson (Apt 101 add.)	111	5550101	7155559877
7	Jane Springfield (Apt 102 add.)	112	5550102	6125556667
8				
9				
10				
11	Mark and Mary Mumbles (Apt 201)	201	5550201	7155557890
12	Martin Freeburg (Apt 202)	202	5550202	7155551347
13	Bob and Pat Hendricks (Apt 203)	203	5550203	6125555555
14	Harry and Jane Warner (Apt 204)	204	5550204	6515559639
15	Mary Mumbles (Apt 201 add.)	211	5550201	7155557891
16	Eric Hendrickson (Apt 203 add.)	213	5550203	6125555556
17	Steve Hendrickson (Apt 203 add.)	223	5550203	6125555557

At the bottom of the window, there are buttons for 'Read Phone Numbers', 'Write Phone Numbers', 'Import', and 'Export'. The background shows other settings panels like 'VoIP Phones Discovered', 'SIP / Network Failure Alarm', and 'Phone Firmware'.

3. Event Log

The Event Log button is used to open the Event Log screen. The Event Log screen shows you the time and date of each event, the event type, relay action (which door/gate was opened or closed), entry code index and phone number index with tenant name. The Event Log can store up to 4,095 events. Events are stored in a first in first out format. When the memory is full, new events will over write the oldest events. The Event log can be saved in one of two file formats: Tab Delimited Text or Comma Separated Variable.

The Event Log window displays the following data:

Event Date / Time	Event Type	Relay Action	Entry Code Index	Phone Number Index
09/23 5:17:43 PM	Keyless	1 Activated	2 - Building Manager	
09/23 5:18:29 PM	Keyless	1 Activated	5 - Thistlewight (Apt 103)	
09/23 5:19:21 PM	Keyless	1 Activated	10 - Warner (Apt 204)	
09/23 5:21:07 PM	Call Begin			1 - Jim and Marge Thompson (Apt 101)
09/23 5:21:13 PM	Call Begin			1 - Jim and Marge Thompson (Apt 101)
09/23 5:21:18 PM	Call End			1 - Jim and Marge Thompson (Apt 101)
09/23 5:23:25 PM	Call Begin			1 - Jim and Marge Thompson (Apt 101)
09/23 5:23:36 PM	Remote	1 Momentary		
09/23 5:23:45 PM	Call End			1 - Jim and Marge Thompson (Apt 101)
09/23 5:24:10 PM	Keyless	1 Activated	7 - Mumbles (Apt 201)	
09/23 5:24:35 PM	Error - Keyless 123123			
09/23 5:24:55 PM	Error - Keyless 1111			
09/23 5:25:33 PM	Keyless	1 Activated	4 - Springfield (Apt 102)	
09/23 5:36:19 PM	Call Begin			13 - Bob and Pat Hendricks (Apt 203)
09/23 5:36:41 PM	Remote	1 Momentary		
09/23 5:36:47 PM	Call End			13 - Bob and Pat Hendricks (Apt 203)
09/23 5:38:46 PM	Keyless	1 Activated	3 - Thompson (Apt 101)	
09/23 5:39:02 PM	Keyless	1 Activated	5 - Thistlewight (Apt 103)	

Buttons at the bottom of the Event Log window: Read, Mark All Read, Read All, Save Event Log.

4. Entry Code Database

Clicking on the “Entry Code Database” button will open the Entry Code Database screen.

The Entry Code Database will then download, this can take over a minute. The Entry Code Database will allow you to program the Relay Function, Relay 1 or 2, once only (one time use only), Entry Type (Card, Keyless or both), Keyless Code, Proximity Card #, Facility Code, Day of week, Time of Day and Tenant Name. Tenant names are stored locally on the PC and are not uploaded.

Index	Relay Function	Relay 1	Relay 2	Once Only	Entry Type	Keyless Code	Card No.	Facility	Su	Mo	Tu	We	Th	Fr	Sa	Start	Stop	Tenant Name
1	Momentary	<input checked="" type="checkbox"/>	<input type="checkbox"/>	<input type="checkbox"/>	Card Only		1000	0	<input checked="" type="checkbox"/>	<input checked="" type="checkbox"/>	<input checked="" type="checkbox"/>	<input checked="" type="checkbox"/>	<input checked="" type="checkbox"/>	<input checked="" type="checkbox"/>	<input checked="" type="checkbox"/>	12:00 AM	11:59 PM	Building Manager
2	Momentary	<input checked="" type="checkbox"/>	<input type="checkbox"/>	<input type="checkbox"/>	Keyless Only	101010	0	0	<input checked="" type="checkbox"/>	<input checked="" type="checkbox"/>	<input checked="" type="checkbox"/>	<input checked="" type="checkbox"/>	<input checked="" type="checkbox"/>	<input checked="" type="checkbox"/>	<input checked="" type="checkbox"/>	12:00 AM	11:59 PM	Building Manager
3	Momentary	<input checked="" type="checkbox"/>	<input type="checkbox"/>	<input type="checkbox"/>	Keyless Only	55101	0	0	<input checked="" type="checkbox"/>	<input checked="" type="checkbox"/>	<input checked="" type="checkbox"/>	<input checked="" type="checkbox"/>	<input checked="" type="checkbox"/>	<input checked="" type="checkbox"/>	<input checked="" type="checkbox"/>	12:00 AM	11:59 PM	Thompson (Apt 101)
4	Momentary	<input checked="" type="checkbox"/>	<input type="checkbox"/>	<input type="checkbox"/>	Keyless Only	55102	0	0	<input checked="" type="checkbox"/>	<input checked="" type="checkbox"/>	<input checked="" type="checkbox"/>	<input checked="" type="checkbox"/>	<input checked="" type="checkbox"/>	<input checked="" type="checkbox"/>	<input checked="" type="checkbox"/>	12:00 AM	11:59 PM	Springfield (Apt 102)
5	Momentary	<input checked="" type="checkbox"/>	<input type="checkbox"/>	<input type="checkbox"/>	Keyless Only	55103	0	0	<input checked="" type="checkbox"/>	<input checked="" type="checkbox"/>	<input checked="" type="checkbox"/>	<input checked="" type="checkbox"/>	<input checked="" type="checkbox"/>	<input checked="" type="checkbox"/>	<input checked="" type="checkbox"/>	12:00 AM	11:59 PM	Thistlewight (Apt 103)
6	Momentary	<input checked="" type="checkbox"/>	<input type="checkbox"/>	<input type="checkbox"/>	Keyless Only	55104	0	0	<input checked="" type="checkbox"/>	<input checked="" type="checkbox"/>	<input checked="" type="checkbox"/>	<input checked="" type="checkbox"/>	<input checked="" type="checkbox"/>	<input checked="" type="checkbox"/>	<input checked="" type="checkbox"/>	12:00 AM	11:59 PM	Parker (Apt 104)
7	Momentary	<input checked="" type="checkbox"/>	<input type="checkbox"/>	<input type="checkbox"/>	Keyless Only	55201	0	0	<input checked="" type="checkbox"/>	<input checked="" type="checkbox"/>	<input checked="" type="checkbox"/>	<input checked="" type="checkbox"/>	<input checked="" type="checkbox"/>	<input checked="" type="checkbox"/>	<input checked="" type="checkbox"/>	12:00 AM	11:59 PM	Mumbles (Apt 201)
8	Momentary	<input checked="" type="checkbox"/>	<input type="checkbox"/>	<input type="checkbox"/>	Keyless Only	55202	0	0	<input checked="" type="checkbox"/>	<input checked="" type="checkbox"/>	<input checked="" type="checkbox"/>	<input checked="" type="checkbox"/>	<input checked="" type="checkbox"/>	<input checked="" type="checkbox"/>	<input checked="" type="checkbox"/>	12:00 AM	11:59 PM	Freeburg (Apt 202)
9	Momentary	<input checked="" type="checkbox"/>	<input type="checkbox"/>	<input type="checkbox"/>	Keyless Only	55203	0	0	<input checked="" type="checkbox"/>	<input checked="" type="checkbox"/>	<input checked="" type="checkbox"/>	<input checked="" type="checkbox"/>	<input checked="" type="checkbox"/>	<input checked="" type="checkbox"/>	<input checked="" type="checkbox"/>	12:00 AM	11:59 PM	Hendricks (Apt 203)
10	Momentary	<input checked="" type="checkbox"/>	<input type="checkbox"/>	<input type="checkbox"/>	Keyless Only	55204	0	0	<input checked="" type="checkbox"/>	<input checked="" type="checkbox"/>	<input checked="" type="checkbox"/>	<input checked="" type="checkbox"/>	<input checked="" type="checkbox"/>	<input checked="" type="checkbox"/>	<input checked="" type="checkbox"/>	12:00 AM	11:59 PM	Wamer (Apt 204)
11	Latch	<input checked="" type="checkbox"/>	<input type="checkbox"/>	<input type="checkbox"/>	Card + Keyless	123123	1000	0	<input checked="" type="checkbox"/>	<input checked="" type="checkbox"/>	<input checked="" type="checkbox"/>	<input checked="" type="checkbox"/>	<input checked="" type="checkbox"/>	<input checked="" type="checkbox"/>	<input checked="" type="checkbox"/>	12:00 AM	11:59 PM	Latch Open (Moving)
12	Un-Latch	<input checked="" type="checkbox"/>	<input type="checkbox"/>	<input type="checkbox"/>	Card + Keyless	911911	1000	0	<input checked="" type="checkbox"/>	<input checked="" type="checkbox"/>	<input checked="" type="checkbox"/>	<input checked="" type="checkbox"/>	<input checked="" type="checkbox"/>	<input checked="" type="checkbox"/>	<input checked="" type="checkbox"/>	12:00 AM	11:59 PM	Emergency Lockdown
13		<input type="checkbox"/>	<input type="checkbox"/>	<input type="checkbox"/>			0	0	<input checked="" type="checkbox"/>	<input checked="" type="checkbox"/>	<input checked="" type="checkbox"/>	<input checked="" type="checkbox"/>	<input checked="" type="checkbox"/>	<input checked="" type="checkbox"/>	<input checked="" type="checkbox"/>	12:00 AM	11:59 PM	
14	Momentary	<input checked="" type="checkbox"/>	<input type="checkbox"/>	<input type="checkbox"/>	Keyless Only	1111	0	0	<input type="checkbox"/>	<input type="checkbox"/>	<input type="checkbox"/>	<input checked="" type="checkbox"/>	<input type="checkbox"/>	<input type="checkbox"/>	<input type="checkbox"/>	1:00 PM	4:00 PM	Decorator for Apt 204
15	Momentary	<input checked="" type="checkbox"/>	<input type="checkbox"/>	<input checked="" type="checkbox"/>	Keyless Only	2222	0	0	<input type="checkbox"/>	<input type="checkbox"/>	<input type="checkbox"/>	<input type="checkbox"/>	<input checked="" type="checkbox"/>	<input type="checkbox"/>	<input type="checkbox"/>	8:00 AM	8:00 PM	Cable Tech for Apt 102
16	Momentary	<input checked="" type="checkbox"/>	<input type="checkbox"/>	<input checked="" type="checkbox"/>	Keyless Only	2222	0	0	<input type="checkbox"/>	<input type="checkbox"/>	<input type="checkbox"/>	<input type="checkbox"/>	<input checked="" type="checkbox"/>	<input type="checkbox"/>	<input type="checkbox"/>	8:00 AM	8:00 PM	Cable Tech for Apt 102 (2nd)
17	Momentary	<input checked="" type="checkbox"/>	<input type="checkbox"/>	<input checked="" type="checkbox"/>	Keyless Only	2222	0	0	<input type="checkbox"/>	<input type="checkbox"/>	<input type="checkbox"/>	<input type="checkbox"/>	<input checked="" type="checkbox"/>	<input type="checkbox"/>	<input type="checkbox"/>	8:00 AM	8:00 PM	Cable Tech for Apt 102 (3rd)
18		<input type="checkbox"/>	<input type="checkbox"/>	<input type="checkbox"/>			0	0	<input checked="" type="checkbox"/>	<input checked="" type="checkbox"/>	<input checked="" type="checkbox"/>	<input checked="" type="checkbox"/>	<input checked="" type="checkbox"/>	<input checked="" type="checkbox"/>	<input checked="" type="checkbox"/>	12:00 AM	11:59 PM	

5. Phone Name

Up to a 32 character phone name can be assigned to the **K-1700-IP** being programmed. Often times the building name and entrance location near the unit are used for the name.

6. Mute Alarm Until Next Failure

A network failure alarm will be indicated by flashing the “Call” LED on the front panel and the speaker outputting 3 beeps every 30 seconds. A network failure indicates the unit is not registered to the SIP server or there is a communication failure with the gateway. The three beeps can be muted by clicking on the “Mute Alarm Until Next Failure”.

7. Phone Firmware

If new **K-1700-IP** firmware is available, after opening the programming software a pop window will come up asking you if you would like to update firmware. An alternative method of updating can be done by clicking the phone firmware “Update” button. You can then browse to the folder that contains the HEX file for updating the unit’s firmware. This method is typically only used when Viking Technical Support has sent you updated firmware.

8. IP Firmware

If new **K-1700-IP** firmware is available, after opening the programming software a pop window will come up asking you if you would like to update firmware. An alternative method of updating can be done by clicking the IP firmware “Update” button. You can then browse to the folder that contains the PIP file for updating the unit’s IP firmware. This method is typically only used when Viking Technical Support has sent you updated IP firmware

9. Import/Export

The Import/Export feature is useful for backing up all the **K-1700-IP**'s programming or for importing programming when installing multiple units with a majority of the same programming.

10. Factory Default

Clicking on the "Factory Default" button in programming will reset all of the Programming Features back to their factory default settings. **Note:** *This command will not change or reset your IP settings.*

11. Diagnostics

The Diagnostics section in the **K-1700-IP** PC Programming can be used to test the functionality of the mic, speaker, proximity card reader, and relays.

12. Security Code

The security code allows the user/installer to program the **K-1700-IP** phone. The factory set security code is 845464. It is recommended that the factory set security code be changed.

Note: *The security code must be 6 digits and cannot include a * or a #.*

13. Access Code

The Access Code is used for remotely operating the relays (Doorstrike, Mag-Lock, etc) by calling into the unit. This code provides basic security and only allows operation of the relays and not the ability to change any of the programming parameters. Once entered, any of the "Remote Access Operation Commands" can be used. The code can be 1 to 6 digits in length and cannot contain a "*" or "#". Simply call the **K-1700-IP** phone, the unit will automatically answer the line and output one beep. You then enter the programmed 1 to 6 digit access code, 2 beeps should be heard. You can now enter any "Remote Access Operation Commands" (see page 19).

14. Auto Answer / Loud Ring

The Auto Answer/Loud Ring feature can be set to one of four modes:

Disabled: In the "Disabled" mode the phone will not automatically answer an incoming call.

Auto Answer (factory setting): In the "Auto Answer" mode the phone will automatically answer an incoming call on the first ring.

Loud Ring: In the "Loud Ring" mode the phone will not automatically answer an incoming call but will output a loud ring signal out of the speaker in a 2 seconds on, 4 seconds off ring pattern. The call can then be answered by momentarily pressing the call button.

Loud Ring with AGC: In the "Loud Ring with AGC" mode the phone will not automatically answer an incoming call but will output a loud ring signal out of the speaker in a 2 seconds on, 4 seconds off ring pattern. The phone will automatically increase or decrease the ring volume based on background ambient noise. The call can then be answered by momentarily pressing the call button.

15. Ring Cadence

When "Auto Answer/Ring" on the **K-1700-IP** is set to "Loud Ring" or "Loud Ring with AGC" the Loud Ring cadence can be programmed to one of 4 different cadences:

Normal Ring (single ring, 2 sec on 4 sec off)

Double Ring (double ring, 1 sec on .5 sec off 1 sec on 3.5 sec off)

Short-Short-Long (triple ring, .5 sec on .5 sec off .5 sec on .5 sec off 1 sec on 3 sec off)

Short-Long-Short (triple ring, .5 sec on .5 sec off 1 sec on .5 sec off .5 sec on 3 sec off)

16. Loud Ring Volume

The Loud Ring Volume can be set from 0 – 9. 1 = the lowest volume, 9 = the highest volume and 0 = disabled.

17. Phone Mode

The Phone Mode can be programmed to one of two settings: Auto Dialer or Manual Dial Phone. When set to Auto Dialer the **K-1700-IP** will auto dial any preprogrammed phone numbers stored in the Phone Number Database when the corresponding Speed Dial Number (example: apartment number) is entered on the unit's keypad. When set to Manual Dial Phone the unit's auto dialing features are disabled and the unit functions as a standard VoIP speaker phone. Pressing the call button will take the phone off hook allowing you to manually dial the phone number on the keypad.

18. Call Button Delay

The Call Button Delay is the length of time from when the Call button is pressed to when the unit starts dialing the Primary number programmed in Phone Number Database Index 0. The time is programmable from 0 to 6 seconds. Adding Call Button Delay time is useful to allow visitors time after they have pressed the Call button to then enter the tenant's apartment number (Speed Dial Number) or their Keyless Entry Code.

19. Call Button Auto Dial

The Call Button Auto Dial feature allows visitors that do not know the tenant's apartment number (Speed Dial Number) a way of simply pressing the Call button with no additional numbers entered. After the Call Button Delay the unit will automatically dial the Primary Phone Number stored in Phone Number Database Index 0. This could route the call to the building manager, care taker, receptionist, etc.

20. Select Time Zone

When using date and time logged events or setting the access date and times of keyless codes or proximity cards in the Entry Code Database, you must program the unit to your time zone. Example: You are installing the **K-1700-IP** in the Central standard time zone: Select (UTC - 06:00) CST, which is 6 hours behind Coordinated Universal Time (UTC).

21. Daylight Savings

The Daylight Saving Time programming can be enabled or disabled and can be programmed to start on any Sunday in March and stopped on any Sunday in November. Currently, daylight saving time starts on the second Sunday in March and ends on the first Sunday in November, with the time changes taking place at 2:00AM local time.

22. Keyless/Card Logging

Keyless Entry Code and Proximity Card logging can be set to Log Errors. With Log Errors selected, the **K-1700-IP** will not only log all valid Keyless Entry Code and Proximity Card entries, but also log any errors, incorrect codes, or non-valid card reads.

Keyless Entry Code and Proximity Card logging can also be set to Live Logging. With Live logging selected and the **K-1700-IP** programming software open and connected to a unit, each Keyless Entry Code entered or Proximity Card read will immediately open the Event Log screen and display the latest entry.

23. Relay Mode

Doorstrike Mode: When programmed for Doorstrike Mode the relay will momentarily activate for the preprogrammed relay activation time after detecting the correct relay activation command (one or two digit touch tone) from the called party.

Outbound Call Mode: When programmed for Outbound Call Mode the relay will activate continuously for the duration of any outbound call from the Entry phone.

Inbound/Outbound Call Mode: When programmed for Inbound/Outbound Call Mode the relay will activate continuously for the duration of any inbound or outbound call to or from the Entry phone. This mode is useful for turning on IR flood lights, for VoIP phones with cameras, etc.

Doorbell Mode: When programmed for Doorbell Mode the relay will momentarily activate the relay for the preprogrammed relay activation time on any outbound call from the Entry phone. This mode is useful for activating a door chime, etc. When activating door chimes, a 0.5 - 1 second relay activation time is recommended.

Alarm Mode: When programmed in Alarm Mode the relay will activate continuously while the Entry phone is powered and registered to the SIP server. In the event the unit loses power and/or SIP registration the relay will turn off, which can be used to signal an alarm device. **NOTE:** *Relay 2 should be set to "Alarm Mode" when mounting a PRX-3 in close proximity of the K-1700-IP (when mounting the K-1700-IP and PRX-3 to a PRX-3-MK-GNP gooseneck pedestal mounting plate) See Pg. 5.*

Loud Ring Mode: When programmed for Loud Ring Mode the relay will continuously activate while the ringing extension is called. This mode is useful for activating a Viking model **SL-2** strobe light, etc.

Loud Ring Flash Mode: When programmed for Loud Ring Flash Mode the relay will momentarily turn on and off in a 400ms on/off cadence while the ringing extension is called. This mode is useful for activating a Viking **LPL-1** Remote Visual Indicator, etc.

24. Relay 1 or 2 (Activation) Command

The one or two digit code stored in the Relay Activation Command is the touch tone command that the person being called must enter on their phone in order to actuate relay 1 or 2 to control a doorstrike, mag-lock, gate controller, or other device. The code can contain the numbers 0 - 9, 00 - 99, ## or ** . The code cannot match a relay latching or toggle command (11, 10, 1#, 21, 20, or 2#). The code must be entered while the remote phone is communicating with the Entry phone. The Entry phone determines which direction the touch tone is coming from and only responds to touch tones from the called phone.

25. Relay 1 or 2 Activation Time

The value stored in the Relay 1 or 2 Activation Time is the amount of time relay 1 or 2 will be energized after a correct touch tone command is entered. This number can range from 0.5 to 99 seconds. The factory setting is 5 seconds.

26. Relay 1 or 2 Internal / External

With relay 1 and/or 2 set to "Internal" the **K-1700-IP** will activate its on board relays for doorstrike / gate control. Relay 1 and/or 2 should be set to "External" for higher security installations when using a Viking model **RC-4A** remote relay controller to activate the doorstrike / gate controller (see page 6). **NOTE:** *With relays set to external the internal on board relays will also activate at the same time as the external relays.*

27. Relay Activation Delay

A relay activation delay of 0.5 to 99 seconds can be programmed in the **K-1700-IP**. A relay activation delay is useful in two door vestibule entrance applications. This allows you to program a delay time from when relay 1 (outside door) is activated to when relay 2 (inside door) is activated. The programmed delay time should be set to the average time it takes a person to walk from the outside door to the inside door.

When a request for exit (REX) is activated, relay 2 will activate first, then after the programmed delay relay 1 will activate.

28. Relay Buzz (Activation Tone) Volume

The relay activation tone is a buzzing sound that is heard at the Entry phone when the door strike relay is activated. After the called party enters the correct relay activation command, the called party will hear 2 short confirmation beeps and the entry phone will output a buzzing sound (relay activation tone) while the door strike relay is activated. The tone (buzz) length will match the relay activation time up to a maximum of 5 seconds. The tone (buzz) can be programmed to three different volume settings 1 = Low, 2 = Medium, 3 = High or it can be disabled.

29. Latch Commands (Enable / Disable Relay Latching Commands)

When programmed to “Enable” (factory default) the Remote Access Operation Commands to Un-Latch or Latch the relay are enabled.

When programmed to “Disable” the Remote Access Operation Commands to Un-Latch or Latch the relay are disabled. Disabling the Latch commands can be useful in applications where you want to eliminate the possibility of inadvertently entering a latch command leaving a gate open/closed, etc.

30. Speaker Mode

The Speaker Mode can be set to one of the following two modes.

OFF/Silent Monitoring Mode: In the “OFF” mode the speaker is disabled on inbound calls. However, the speaker can be enabled after communication has been established by entering touch tone command “9#”. The speaker will then remain on for the duration of the call.

ON (factory setting): In the “ON” mode the speaker is enabled during In-bound and Out-bound calls.

31. Speaker Volume

The speaker volume can be set from 0 to 9 (0 = lowest volume setting, 9 = the highest, factory set to 2). Alternatively the speaker can be turned off for silent monitoring (see Speaker Mode section 30).

32. Microphone Volume / Automatic Noise Cancelling Mode

The microphone volume can be set from 1 to 9 (1 = lowest volume setting, 9 = the highest, factory set to 5). Alternatively the microphone can be placed in the “ANC” Automatic Noise Cancelling mode. With the mic in the ANC mode, when background noise increases, the mic gain will automatically decrease. When background noise decreases the mic gain will automatically increase. The ANC mode is useful in applications where the background noise level can change drastically such as a gas car running vs a diesel truck.

33. Talk / Listen Delay (VOX)

This feature selects switching time between talk and listen modes (VOX switching time). The Talk/Listen Delay can be programmed from .1 to .9 seconds.

Note: The factory default is .5 seconds.

34. Audio Call Progress (In-Band Audio Call Progress Detection)

The In-Band Audio Call Progress Detection can be set to enabled or disabled. In-Band Audio Call Progress detection should be enabled in applications where you are making an outbound call through your VoIP phone system and are relying on In-Band analog audio for ringback or busy detection. The factory default is: enabled.

35. Audio Detect Level (In-Band Audio Detection Level / Sensitivity)

The In-Band Audio Detection level (Sensitivity) can be set from 1 to 9 (1 = minimum setting, 9 = the highest, factory set to 5). Increasing or decreasing the sensitivity may be required in applications where you are making an outbound call through your VoIP phone system and are relying on In-Band analog audio detection.

36. Call Length Time Out

This feature selects the maximum length of time that calls can be connected. Programmable in increments of 1 minute up to a maximum of 9 minutes or disabled. With the call length disabled, the **K-1700-IP** phone must rely on a call ended signal, busy signal, silence or return to dial tone to hang-up.

Note: *The factory default is 3 minutes.*

37. Dial Next # on RNA (Ring No Answer)

If enabled and a ring-no-answer is detected, the **K-1700-IP** phone will dial the “Roll Over” speed dial number.

Note: *Factory set to redial if not answered after 7 rings.*

38. Dial Next # on Busy

If enabled and a busy is detected, the **K-1700-IP** phone will dial the “Roll Over” speed dial number. **Notes:** *This feature is enabled in the factory default setting. If the busy signal is interrupted with a promotional message, contact your central office to have it removed.*

39. Live Dialing Format

The Live Dialing Format can be set to In-Band DTMF (Touch Tones) or RFC 2833 (Out of Band DTMF Touch Tones). Live dialing refers to the numbers dialed after an outbound call has been answered by the distant party. This would typically be the numbers dialed to steer through automated attendants, voice mail, etc. If your VoIP phone system does not automatically convert out of band DTMF to In-Band after the call is answered, set Live Dialing Format to “Inband DTMF”.

40. REX Input

The **K-1700-IP** has one Request for Exit (REX) trigger input. The REX switch must have a momentary, normally open contact. When the **K-1700-IP** detects a contact closure on the REX trigger input it performs one of the following actions, based on the Relay Mode settings (see section 23):

Relay 1 "Door Strike", relay 2 other: Relay 1 will be activated for the programmed Relay 1 Activation Time.

Relay 1 other, relay 2 "Door Strike": Relay 2 will be activated for the programmed Relay 2 Activation Time.

Relay 1 "Door Strike", relay 2 "Door Strike": Relay 2 will be activated for the programmed Relay 2 Activation Time, then after the Relay Activation Delay time has passed, relay 1 will be activated for the programmed Relay 1 Activation Time. This is useful in two door vestibule applications where relay 1 is used to unlock the outside door, and relay 2 is used to unlock the inside door.

Operation

A. “CALL” Button

With the call button Auto Dial Delay set to No Delay (factory default), when the “CALL” button is pressed, the **K-1700-IP** immediately dials the pre-programmed telephone number stored in the Phone Number Database Index location 0. With the call button Auto Dial Delay set from 1 - 6, when the “CALL” button is pressed you will hear 1 - 6 seconds of dial tone, allowing you time to enter the 1-3 digit Speed Dial number. The unit will then dial the Phone Number Database Index location 0-250 associated with the preprogrammed 1-3 digit Speed Dial Number (0-999). The Call Status LED momentarily flashes during dialing. In the event the line is busy or there is a ring-no-answer, the unit can be programmed to call a second roll over number.

When the call is answered, relay activation commands can be entered or the # key can be used to force the phone to hang-up.

After communication is established, enter the 1 or 2 digit relay activation command (factory set to “**” for Relay 1 and “*2” for Relay 2) to momentarily activate the entry phone (door strike) relay. Two beeps will be heard confirming that the relay has been activated. If you require the relay to remain on continuously (ie: a truck delivery), enter Touch Tones “11” or “21” to continuously activate relay 1 or relay 2 respectively. A double beep will indicate that the relay is latched on. When the visitor calls in again (ie: they are finished unloading the truck), enter Touch Tones “10” or “20” to deactivate relay 1 or relay 2 respectively. A single beep will indicate the relay is latched off.

B. Remote Access Operation Commands

The following commands can be entered after answering an inbound call from the entry phone. The commands can also be entered on an outbound call to the entry phone. After the entry phone auto answers the call, one or two beeps will be heard. If the access code has been disabled (two beeps heard), you can now enter the Remote Access Operation Commands below. If an Access code has been programmed (one beep heard), enter the Access code digits. With the correct code entered, two beeps will be heard and you can now enter the Remote Access Operation Commands below. The relay must be set to "Door Strike" Mode to be controlled by these commands.

Feature	Touch Tone Command	Description
Momentarily Activate Relay 1	** or ____	Momentarily activate relay 1 (1 or 2 digits, factory set to **).
Latch Relay 1	11	Latch* (continuously activate) relay 1.
Un-Latch Relay 1	10	Un-latch* (deactivate) relay 1.
Toggle Relay 1	1#	Toggle relay 1 from last position.
Momentarily Activate Relay 2	*2 or ____	Momentarily activate relay 2 (1 or 2 digits, factory set to *2).
Latch Relay 2	21	Latch* (continuously activate) relay 2.
Un-Latch Relay 2	20	Un-latch* (deactivate) relay 2.
Toggle Relay 2	2#	Toggle relay 2 from last position.
Disconnect	#	Disconnects or forces the phone to hang up.

* **Note:** Latching commands must be enabled in programming.

C. Keyless Entry Codes and One Time Use Keyless Entry Codes

Keyless entry codes may be used by the tenants to provide keyless entry. The **K-1700-IP** can be programmed with a combination of up to 1000* keyless entry codes or one time use keyless entry codes. The keyless entry codes can be programmed to be from 1 to 6 digits in length. Each keyless entry code can be programmed to activate relay 1 and/or 2 in four different relay modes: Momentary, Latch, Un-Latch and Toggle. To use a keyless entry code the tenant simply dials "#" followed by the entry code on the **K-1700-IP's** keypad. After the one time use keyless entry code has been used, it is instantly cleared from the unit's memory. This is ideal for issuing keyless entry codes to service personnel, etc.

Note: A short buzz sound indicates when the relay has been activated and the visitor can now open the door.

D. Proximity Cards

Proximity cards can also be used by the tenants to provide keyless entry. The **K-1700-IP** can be programmed with up to 1000* proximity card numbers. Each proximity card number can be programmed to activate relay 1 and/or 2 in four different relay modes: Momentary, Latch, Un-Latch and Toggle. To use a proximity card the tenant simply presents a preprogrammed proximity card within 6 inches of the proximity card reader attached to the **K-1700-IP**. A short beep will be heard from the card reader indicating a card scan. If the card matches a valid preprogrammed card number a short buzz sound will be heard indicating the relay has been activated and the visitor can now open the door or gate.

***Note:** 1000 is the total number of Keyless Entry Codes and/or Proximity Card numbers that can be programmed in the Entry Code Database.

Troubleshooting

If the unit cannot register with the programmed SIP server, the LED will blink on and off every two seconds, and three error beeps will be heard every 30 seconds until communication is restored. This alerts a potential user of a problem with the device that will prevent an emergency phone call from being made.

You may silence the error beeps, per instance, by pressing and holding the CALL button for 5 seconds or by clicking the "Mute Alarm Until Next Failure" button in the Viking K-1700-IP Programming Software (see section **A** on page 7). The error beeps automatically re-enable once the unit is registered, to alert of any new problems that arise.

Surface or Pedestal Mount Viking Products While Maintaining Weather and Vandal Resistance

The **VE-3x5**, **VE-5x5**, **VE-6x7** and **VE-5x10** add vandal and weather resistance, as well as versatility to many Viking products. The **VE-Series** backboxes are available in black fine texture powder painted steel or marine grade 316 stainless steel. The weather resistant boxes are designed to be surface mounted to a wall, post, single gang box, or a **VE-GNP** gooseneck pedestal.

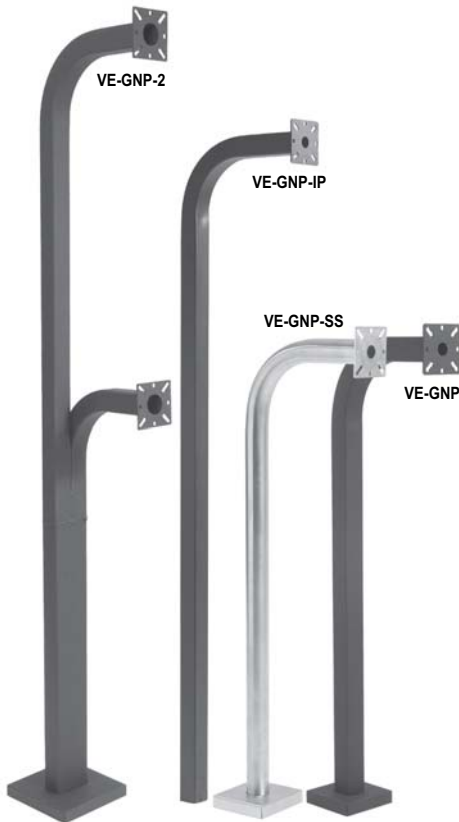

The **VE-GNP** gooseneck pedestals are designed to be used with the **VE-5x5**, **VE-6x7** and **VE-5x10** backboxes and are ideal for drive up communications. **Note:** The **VE-3x5** is not compatible with the **VE-GNP** pedestals.

The **VE-PNL**'s are **VE-Series** backboxes with a blank aluminum panel. The user can customize the clear-coated aluminum panel to mount an **PRX-1** card reader, **PRX-2** keypad or switch. The kits come complete with box, gasket, panel and screws. Model numbers that end with "SS" are stainless steel version. **Note:** The use of magnets to mount the **VE-Series** enclosure to a metal surface can affect the operation of the enclosed product.

For more information, see **DOD# 424**.

Add Panel Lighting to Your Viking VoIP Entry Phone

The **VE-LIGHT** kit adds bright LED illumination to any VoIP entry phone that is housed in a Viking **VE-5x5**, **VE-6x7** or **VE-5x10** enclosure.

The stainless steel bracket is easily mounted using existing holes and hardware. Two bright white LEDs are used as the light source, so there are no filaments to break or bulbs to burn out.

12 VDC power adapter included. Any power source between 12 and 24 volts, AC or DC can be used to supply the **VE-LIGHT** with power.

For more information, See **DOD# 428**.

VE-LIGHT shown right with Viking E-30 and VE-5x5 (not included)



Control Relay Contacts Across a Local Area Network

The **RC-4A** Network Enabled Relay Controller provides networked control of four relays via an easy-to-use web interface. The same interface can be used to check the status of four contact closure inputs. Relays can be toggled on or off, or user-programmed timed closures can be activated.

The **RC-4A** can be configured to work as a remote relay for Viking VoIP series entry phones, controlling door strikes and gates when a remote relay is required for security reasons. It can also be programmed to send an email or text message in response to a change in one or more of the sensor inputs. Two **RC-4A's** can be set up so that activity on a sensor input of one unit will automatically send a message across the network to activate one of the relays on the other unit. Two levels of user access permit selected users to have full operational and programming rights while others have operational control but not programming capability. For more info, see **DOD# 585**.



125KHz Proximity Card Reader



PRX-1

The model **PRX-1** is a 125KHz proximity card reader and is designed to be mounted directly to a metal door or window frame (mullions), making it ideal for applications requiring an access credential. The proximity card reader transmits data in 26-Bit Wiegand format, making it compatible with any of the Wiegand equipped Viking entry controllers.

The **PRX-1** delivers non-contact read ranges up to 6 inches (152 mm), and operates from 5 to 14 VDC. Physical size is a compact 3.2 x 1.7 x 0.70 inches (80 x 43 x 17 mm). Mounting is simplified with horizontal and vertical mounting slots, which allow the reader to be conveniently adjusted and leveled. To allow both indoor and outdoor operation the electronics are sealed in tamper resistant epoxy potting. Concealing the mounting hardware, the **PRX-1** ships with both Black and Ash (Off-White) covers standard. See **DOD# 221** for more information.

125KHz Proximity Cards

The **PRX-C** and **PRX-C-ISO** are non-contact security cards that can be presented to the front of a **K-1770/75-IP** proximity card reader to allow entrance into a secured area. The **PRX-C** is a clam shell card made made from 0.070" thick plastic to resist bending and folding. A slot is provided at one end to allow a lanyard to be added for creating a "dog tag" style neck strap. The **PRX-C-ISO** is a thin 0.032" thick flexible "ISO" style proximity card. Much like a credit card, the **PRX-C-ISO** is perfect for storing in your wallet.



The **PRX-FOB** is a proximity key ring fob with brass eyelet designed to attach to a key chain or necklace. The **PRX-FOB's** compact size is only 1.5" x 1.2" x 0.15" making it one of the smallest available.

The cards and fobs are custom pre-programmed. For more information see **DOD# 198**.

Medium Range 125KHz Proximity Card Reader



The model **PRX-3** is a high performance medium range 125KHz proximity card reader. The **PRX-3's** compact size yet long read range of up to 16 inches* make it ideal for parking control, gate access, turnstiles, etc. It is designed to be mounted directly to a wall, post, single gang

electrical box or use an optional mounting kit for attaching it to a gooseneck pedestal. Mounting is simplified with horizontal and vertical mounting slots, which allow the reader to be conveniently adjusted and leveled. To increase vandal resistance the chassis is a single piece design with the mounting screws concealed behind a UV stable label.

The proximity card reader transmits data in 26-Bit Wiegand format, making it compatible with any of the Wiegand equipped Viking entry controllers. The **PRX-3** is equipped with Enhanced Weather Protection (EWP) for outdoor installations. With its sealed connections and fully potted electronics the **PRX-3** is designed to meet an IP66 Ingress Protection Rating. See **DOD# 228** for info.

Gooseneck Pedestal Mounting Kit

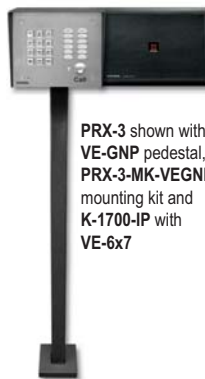

PRX-3 shown with VE-GNP pedestal, PRX-3-MK-VEGNP mounting kit and K-1700-IP with VE-6x7

The model **PRX-3-MK-VEGNP** is a mounting kit for attaching the **PRX-3** proximity card reader and a **VE-5x5**, **VE-6x7** or **VE-5x10** (surface mount entry phone box) to a **VE-GNP** gooseneck pedestal. It includes the required mounting hardware, has a mounting plate made from durable 3/8 inch thick black UV stable textured ABS plastic and a gasket for sealing the back side of the VE surface mount box.



For more info see **DOD# 229**

Warranty

IF YOU HAVE A PROBLEM WITH A VIKING PRODUCT, CONTACT: VIKING TECHNICAL SUPPORT AT (715) 386-8666

Our Technical Support Department is available for assistance Monday 8am - 4pm and Tuesday through Friday 8am - 5pm central time. So that we can give you better service, before you call please:

1. Know the model number, the serial number and what software version you have (see serial label).
2. Have your Product Manual in front of you.
3. It is best if you are on site.

RETURNING PRODUCT FOR REPAIR

The following procedure is for equipment that needs repair:

1. Customer must contact Viking's Technical Support Department at 715-386-8666 to obtain a Return Authorization (RA) number. The customer MUST have a complete description of the problem, with all pertinent information regarding the defect, such as options set, conditions, symptoms, methods to duplicate problem, frequency of failure, etc.
2. Packing: Return equipment in original box or in proper packing so that damage will not occur while in transit. Static sensitive equipment such as a circuit board should be in an anti-static bag, sandwiched between foam and individually boxed. All equipment should be wrapped to avoid packing material lodging in or sticking to the equipment. Include ALL parts of the equipment. C.O.D. or freight collect shipments cannot be accepted. Ship cartons prepaid to: **Viking Electronics, 1531 Industrial Street, Hudson, WI 54016**
3. Return shipping address: Be sure to include your return shipping address inside the box. We cannot ship to a PO Box.
4. RA number on carton: In large printing, write the R.A. number on the outside of each carton being returned.

RETURNING PRODUCT FOR EXCHANGE

The following procedure is for equipment that has failed out-of-box (within 10 days of purchase):

1. Customer must contact Viking's Technical Support at 715-386-8666 to determine possible causes for the problem. The customer MUST be able to step through recommended tests for diagnosis.
2. If the Technical Support Product Specialist determines that the equipment is defective based on the customer's input and troubleshooting, a Return Authorization (R.A.) number will be issued. This number is valid for fourteen (14) calendar days from the date of issue.
3. After obtaining the R.A. number, return the approved equipment to your distributor, referencing the R.A. number. Your distributor will then replace the Viking product using the same R.A. number.
4. **The distributor will NOT exchange this product without first obtaining the R.A. number from you. If you haven't followed the steps listed in 1, 2 and 3, be aware that you will have to pay a restocking charge.**

TWO YEAR LIMITED WARRANTY

Viking warrants its products to be free from defects in the workmanship or materials, under normal use and service, for a period of two years from the date of purchase from any authorized Viking distributor. If at any time during the warranty period, the product is deemed defective or malfunctions, return the product to Viking Electronics, Inc., 1531 Industrial Street, Hudson, WI., 54016. Customer must contact Viking's Technical Support Department at 715-386-8666 to obtain a Return Authorization (R.A.) number.

This warranty does not cover any damage to the product due to lightning, over voltage, under voltage, accident, misuse, abuse, negligence or any damage caused by use of the product by the purchaser or others. This warranty does not cover non-EWP products that have been exposed to wet or corrosive environments. This warranty does not cover stainless steel surfaces that have not been properly maintained.

NO OTHER WARRANTIES. VIKING MAKES NO WARRANTIES RELATING TO ITS PRODUCTS OTHER THAN AS DESCRIBED ABOVE AND DISCLAIMS ANY EXPRESS OR IMPLIED WARRANTIES OR MERCHANTABILITY OR FITNESS FOR ANY PARTICULAR PURPOSE.

EXCLUSION OF CONSEQUENTIAL DAMAGES. VIKING SHALL NOT, UNDER ANY CIRCUMSTANCES, BE LIABLE TO PURCHASER, OR ANY OTHER PARTY, FOR CONSEQUENTIAL, INCIDENTAL, SPECIAL OR EXEMPLARY DAMAGES ARISING OUT OF OR RELATED TO THE SALE OR USE OF THE PRODUCT SOLD HEREUNDER.

EXCLUSIVE REMEDY AND LIMITATION OF LIABILITY. WHETHER IN AN ACTION BASED ON CONTRACT, TORT (INCLUDING NEGLIGENCE OR STRICT LIABILITY) OR ANY OTHER LEGAL THEORY, ANY LIABILITY OF VIKING SHALL BE LIMITED TO REPAIR OR REPLACEMENT OF THE PRODUCT, OR AT VIKING'S OPTION, REFUND OF THE PURCHASE PRICE AS THE EXCLUSIVE REMEDY AND ANY LIABILITY OF VIKING SHALL BE SO LIMITED.

IT IS EXPRESSLY UNDERSTOOD AND AGREED THAT EACH AND EVERY PROVISION OF THIS AGREEMENT WHICH PROVIDES FOR DISCLAIMER OF WARRANTIES, EXCLUSION OF CONSEQUENTIAL DAMAGES, AND EXCLUSIVE REMEDY AND LIMITATION OF LIABILITY, ARE SEVERABLE FROM ANY OTHER PROVISION AND EACH PROVISION IS A SEPARABLE AND INDEPENDENT ELEMENT OF RISK ALLOCATION AND IS INTENDED TO BE ENFORCED AS SUCH.

If trouble is experienced with the **K-1700-IP** phone, for repair or warranty information, please contact:

Viking Electronics, Inc., 1531 Industrial Street, Hudson, WI 54016 (715) 386-8666

WHEN PROGRAMMING EMERGENCY NUMBERS AND (OR) MAKING TEST CALLS TO EMERGENCY NUMBERS:

Remain on the line and briefly explain to the dispatcher the reason for the call. Perform such tests in off-peak hours, such as early morning or late evenings.

PART 15 LIMITATIONS

This equipment has been tested and found to comply with the limits for a Class A digital device, pursuant to Part 15 of the FCC Rules. These limits are designed to provide reasonable protection against harmful interference when the equipment is operated in a commercial environment. This equipment generates, uses, and can radiate radio frequency energy and, if not installed and used in accordance with the instruction manual, may cause harmful interference to radio communications. Operation of this equipment in a residential area is likely to cause harmful interference in which case the user will be required to correct the interference at his own expense.

Product Support: (715) 386-8666

Due to the dynamic nature of the product design, the information contained in this document is subject to change without notice. Viking Electronics, and its affiliates and/or subsidiaries assume no responsibility for errors and omissions contained in this information. Revisions of this document or new editions of it may be issued to incorporate such changes.