

## Allow Three Emergency Phones to Share a Single Line



The LC-3 Line Concentrator allows up to three emergency phones to share a single line. A call initiated by any emergency phone is given the line. If a second emergency phone attempts to make a call while another emergency call is in use, the LC-3 will provide a busy signal until the line is available. Viking emergency phones can be programmed to redial on busy.

All inbound calls are answered by the LC-3. The emergency personnel then dials a touch tone command to connect to one of three phones.

A Fire Floor Phone port is provided as a means for local dedicated telephones to directly connect to any of the three emergency phones.

A secondary mode of operation allows two emergency phones to share an existing analog line of a phone system.

### Features

- Automatic answering of inbound calls
- Inbound calls can be Touch Tone transferred to any port
- Connects up to 3 emergency phones, or 2 phones can share a line with a phone system
- Fire Floor Phone port provided to meet elevator code
- Modular connection for easy installation
- During power outages, the emergency phones are all connected to the phone line

### Applications

- Sharing one line with three Emergency Phones
- Where elevator code requires a "means for emergency personnel within the building to establish two way voice communication to each car individually"

### Specifications

- Power:** 120V AC/13.8V AC 1.25A UL listed adapter provided  
**Dimensions:** 127mm x 127mm x 38mm (5" x 5" x 1.5")  
**Shipping Weight:** 0.9 Kg (2 lbs)  
**Environmental:** 0°C to 32°C (32°F to 90°F) with 5% to 95% non-condensing humidity  
**Talk Battery Voltage:** 32VDC  
**Connections:** (5) RJ-11 modular jacks

## IF YOU HAVE A PROBLEM WITH A VIKING PRODUCT, PLEASE CONTACT: VIKING TECHNICAL SUPPORT AT (715) 386-8666

Our Technical Support Department is available for assistance Monday 8am - 4pm and Tuesday through Friday 8am - 5pm central time. So that we can give you better service, before you call please:

1. Know the model number, the serial number and what software version you have (see serial label).
2. Have your Technical Practice in front of you.
3. It is best if you are on site.

### RETURNING PRODUCT FOR REPAIR

The following procedure is for equipment that needs repair:

1. Customer must contact Viking's Technical Support Department at 715-386-8666 to obtain a Return Authorization (RA) number. The customer MUST have a complete description of the problem, with all pertinent information regarding the defect, such as options set, conditions, symptoms, methods to duplicate problem, frequency of failure, etc.
2. Packing: Return equipment in original box or in proper packing so that damage will not occur while in transit. Static sensitive equipment such as a circuit board should be in an anti-static bag, sandwiched between foam and individually boxed. All equipment should be wrapped to avoid packing material lodging in or sticking to the equipment. Include ALL parts of the equipment. C.O.D. or freight collect shipments cannot be accepted. Ship cartons prepaid to: **Viking Electronics, 1531 Industrial Street, Hudson, WI 54016**
3. Return shipping address: Be sure to include your return shipping address inside the box. We cannot ship to a PO Box.
4. RA number on carton: In large printing, write the R.A. number on the outside of each carton being returned.

### RETURNING PRODUCT FOR EXCHANGE

The following procedure is for equipment that has failed out-of-box (within 10 days of purchase):

1. Customer must contact Viking's Technical Support at 715-386-8666 to determine possible causes for the problem. The customer MUST be able to step through recommended tests for diagnosis.
2. If the Technical Support Product Specialist determines that the equipment is defective based on the customer's input and troubleshooting, a Return Authorization (R.A.) number will be issued. This number is valid for fourteen (14) calendar days from the date of issue.
3. After obtaining the R.A. number, return the approved equipment to your distributor, referencing the R.A. number. Your distributor will then replace the product over the counter at no charge. The distributor will then return the product to Viking using the same R.A. number.
4. **The distributor will NOT exchange this product without first obtaining the R.A. number from you. If you haven't followed the steps listed in 1, 2 and 3, be aware that you will have to pay a restocking charge.**

### LIMITED WARRANTY

Viking warrants its products to be free from defects in the workmanship or materials, under normal use and service, for a period of one year from the date of purchase from any authorized Viking distributor or 18 months from the date manufactured, which ever is greater. If at any time during the warranty period, the product is deemed defective or malfunctions, return the product to Viking Electronics, Inc., 1531 Industrial Street, Hudson, WI., 54016. Customer must contact Viking's Technical Support Department at 715-386-8666 to obtain a Return Authorization (R.A.) number.

This warranty does not cover any damage to the product due to lightning, over voltage, under voltage, accident, misuse, abuse, negligence or any damage caused by use of the product by the purchaser or others.

**NO OTHER WARRANTIES.** VIKING MAKES NO WARRANTIES RELATING TO ITS PRODUCTS OTHER THAN AS DESCRIBED ABOVE AND DISCLAIMS ANY EXPRESS OR IMPLIED WARRANTIES OR MERCHANTABILITY OR FITNESS FOR ANY PARTICULAR PURPOSE.

**EXCLUSION OF CONSEQUENTIAL DAMAGES.** VIKING SHALL NOT, UNDER ANY CIRCUMSTANCES, BE LIABLE TO PURCHASER, OR ANY OTHER PARTY, FOR CONSEQUENTIAL, INCIDENTAL, SPECIAL OR EXEMPLARY DAMAGES ARISING OUT OF OR RELATED TO THE SALE OR USE OF THE PRODUCT SOLD HEREUNDER.

**EXCLUSIVE REMEDY AND LIMITATION OF LIABILITY.** WHETHER IN AN ACTION BASED ON CONTRACT, TORT (INCLUDING NEGLIGENCE OR STRICT LIABILITY) OR ANY OTHER LEGAL THEORY, ANY LIABILITY OF VIKING SHALL BE LIMITED TO REPAIR OR REPLACEMENT OF THE PRODUCT, OR AT VIKING'S OPTION, REFUND OF THE PURCHASE PRICE AS THE EXCLUSIVE REMEDY AND ANY LIABILITY OF VIKING SHALL BE SO LIMITED.

IT IS EXPRESSLY UNDERSTOOD AND AGREED THAT EACH AND EVERY PROVISION OF THIS AGREEMENT WHICH PROVIDES FOR DISCLAIMER OF WARRANTIES, EXCLUSION OF CONSEQUENTIAL DAMAGES, AND EXCLUSIVE REMEDY AND LIMITATION OF LIABILITY, ARE SEVERABLE FROM ANY OTHER PROVISION AND EACH PROVISION IS A SEPARABLE AND INDEPENDENT ELEMENT OF RISK ALLOCATION AND IS INTENDED TO BE ENFORCED AS SUCH.

### FCC REQUIREMENTS

This equipment complies with Part 68 of the FCC rules and the requirements adopted by the ACTA. On the side of this equipment is a label that contains, among other information, a product identifier in the format US:AAAEQ##TXXXX. If requested, this number must be provided to the telephone company.

The REN is used to determine the number of devices that may be connected to a telephone line. Excessive REN's on a telephone line may result in the devices not ringing in response to an incoming call. In most but not all areas, the sum of the REN's should not exceed five (5.0). To be certain of the number of devices that may be connected to a line, as determined by the total REN's, contact the local telephone company. For products approved after July 23, 2001, the REN for this product is part of the product identifier that has the format US:AAAEQ##TXXXX. The digits represented by ## are the REN without a decimal point (e.g., 03 is a REN of 0.3). For earlier products, the REN is separately shown on the label.

The plug used to connect this equipment to the premises wiring and telephone network must comply with the applicable FCC Part 68 rules and requirements adopted by the ACTA. If your home has specially wired alarm equipment connected to the telephone line, ensure the installation of this DNA-510 does not disable your alarm equipment. If you have questions about what will disable alarm equipment, consult your telephone company or a qualified installer.

If the DNA-510 causes harm to the telephone network, the telephone company will notify you in advance that temporary discontinuance of service may be required. But if advance notice isn't practical, the telephone company will notify the customer as soon as possible. Also, you will be advised of your right to file a complaint with the FCC if you believe it is necessary.

The telephone company may make changes in its facilities, equipment, operations, or procedures that could affect the operation of the equipment. If this happens, the telephone company will provide advance notice in order for you to make

the necessary modifications to maintain uninterrupted service.

If trouble is experienced with the DNA-510, for repair or warranty information, please contact:

**Viking Electronics, Inc., 1531 Industrial Street, Hudson, WI 54016 (715) 386-8666**

If the equipment is causing harm to the telephone network, the telephone company may request that you disconnect the equipment until the problem is resolved.

Connection to Party Line Service is subject to State Tariffs. Contact the state public utility commission, public service commission or corporation commission for information.

**WHEN PROGRAMMING EMERGENCY NUMBERS AND (OR) MAKING TEST CALLS TO EMERGENCY NUMBERS:**

Remain on the line and briefly explain to the dispatcher the reason for the call. Perform such activities in the off-peak hours, such as early morning or late evenings.

It is recommended that the customer install an AC surge arrester in the AC outlet to which this device is connected. This is to avoid damaging the equipment caused by local lightning strikes and other electrical surges.

### PART 15 LIMITATIONS

This equipment has been tested and found to comply with the limits for a Class A digital device, pursuant to Part 15 of the FCC Rules. These limits are designed to provide reasonable protection against harmful interference when the equipment is operated in a commercial environment. This equipment generates, uses, and can radiate radio frequency energy and, if not installed and used in accordance with the instruction manual, may cause harmful interference to radio communications. Operation of this equipment in a residential area is likely to cause harmful interference in which case the user will be required to correct the interference at his own expense.

## Features Overview

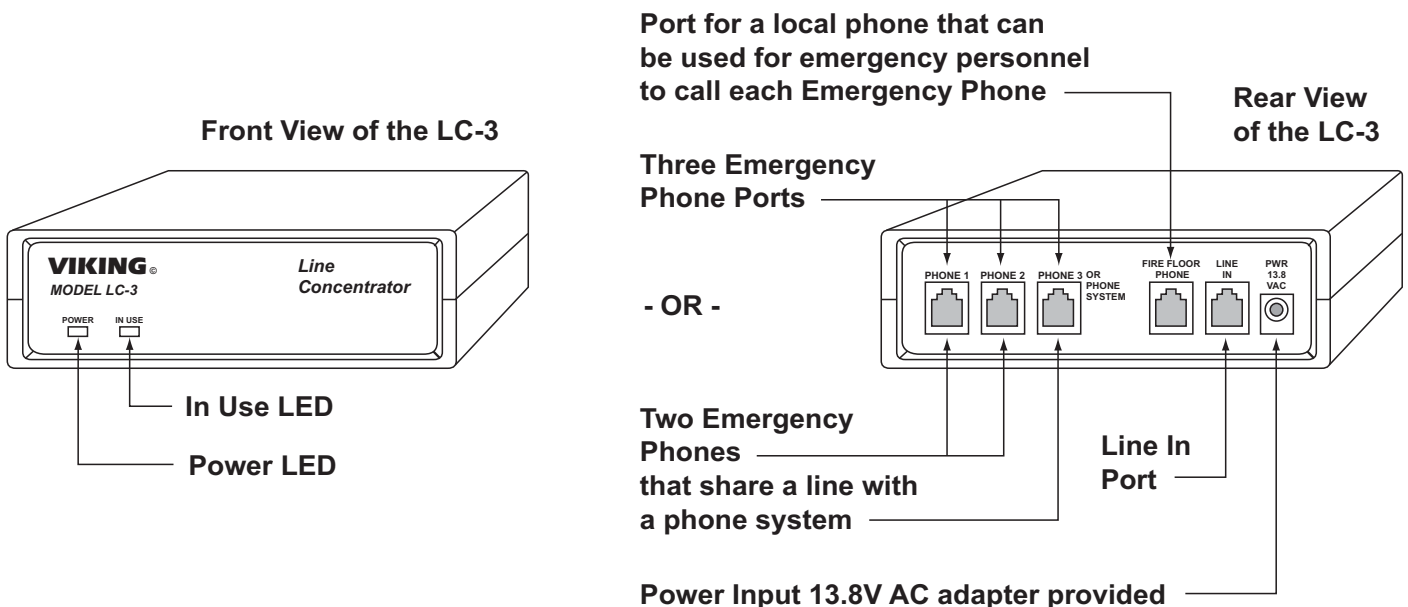

# Installation

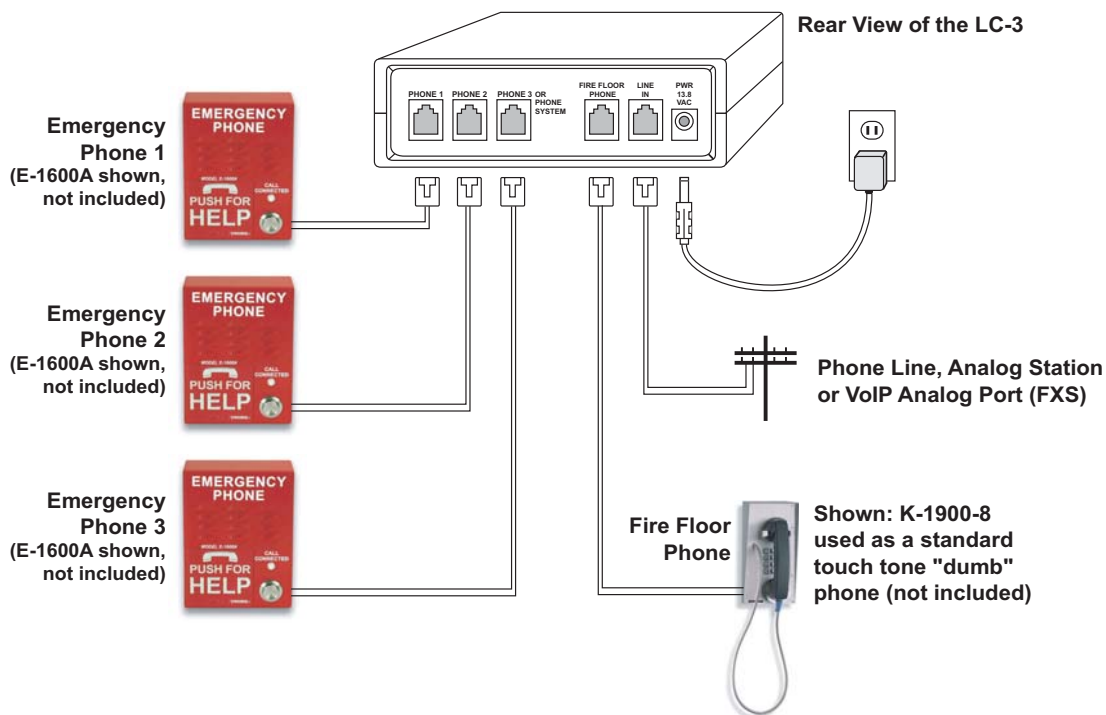

# Operation

## A. Front Panel LEDs

The LC-3 has two front panel LEDs. The "POWER" LED lights to show the unit is powered up. The "IN USE" LED lights whenever any of the phones are in use.

## B. Outbound Calls

Any of the three emergency phones can make an outbound call to the phone line through the LC-3. If a second emergency phone attempts to make a call while another emergency phone is in use, the LC-3 will provide a busy signal until the line is available. Viking emergency phones can be programmed to redial on busy, this way the second emergency phone will continue to try until it is able to place a call for help.

## C. Inbound Calls

The LC-3 immediately answers the ringing line and gives a double beep indicating it has answered. The person calling in then has 4 seconds to enter a single touch tone "1", "2" or "3" before it drops the line. If a single touch tone is detected, the LC-3 will ring-through to emergency phone port 1, 2 or 3 respectively. All Viking emergency phones are set up to automatically answer a ringing line. Once answered, the inbound call has talk path to that emergency phone.

## D. Fire Floor Phone

The Fire Floor Phone port provides 32 volts of DC talk battery to operate a Fire Floor Phone (any standard single line touch tone phone can be used). When the Fire Floor Phone comes off-hook, the LC-3 gives a double beep. At any time, a single touch tone "1", "2" or "3" can be entered to call emergency phone port 1, 2 or 3. This means emergency personnel do not even need to hang up the Fire Floor Phone to call another emergency phone. It is recommended the Fire Floor Phone has access limited to authorized personnel only. It would also be beneficial to mark the Fire Floor Phone as such, and label the touch tone keypad as to which elevators of the three keys dial.

## E. Power Fail Condition

If power is lost to the LC-3, all three emergency phones will be connected directly to the phone line within the LC-3. In this state any of the three emergency phones can make an outbound call to the phone line through the LC-3 even though the LC-3 has no power. A second emergency phone could then barge into the same call, but Viking emergency phones have a privacy feature that prevents this from happening. Additional emergency phones can make their own call for help, once the line is again available. If the Fire Floor Phone functionality is required during a power outage, the LC-3 needs to be plugged into an uninterruptable back-up power supply (UPS) so that power is not lost.

## F. Prank Condition

An emergency phone that is left off-hook is considered a prank phone. When the **LC-3** is left in this state, the other emergency phones can not make a call for help. Prevent prank phones by installing Viking emergency phones, as they intelligently know when to automatically hang up. It is also important to install the Fire Floor Phone with access restricted to authorized personnel only because when the Fire Floor Phone is off hook, the phone line is not available.

# Alternate Application

## Sharing a Line with a Phone System

A secondary mode of operation allows two emergency phones to share an existing analog line of a phone system. With the power disconnected, remove the **LC-3**'s cover and place the shunt so that it is on both pins JP1 (see diagram to the right). Wire the installation as shown below.

Internal View of the LC-3

JP1

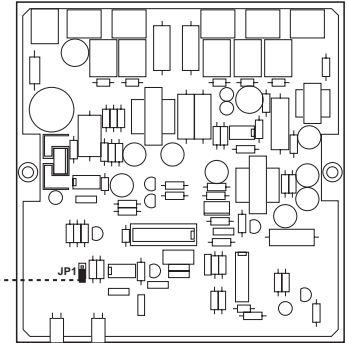

Rear View of the LC-3

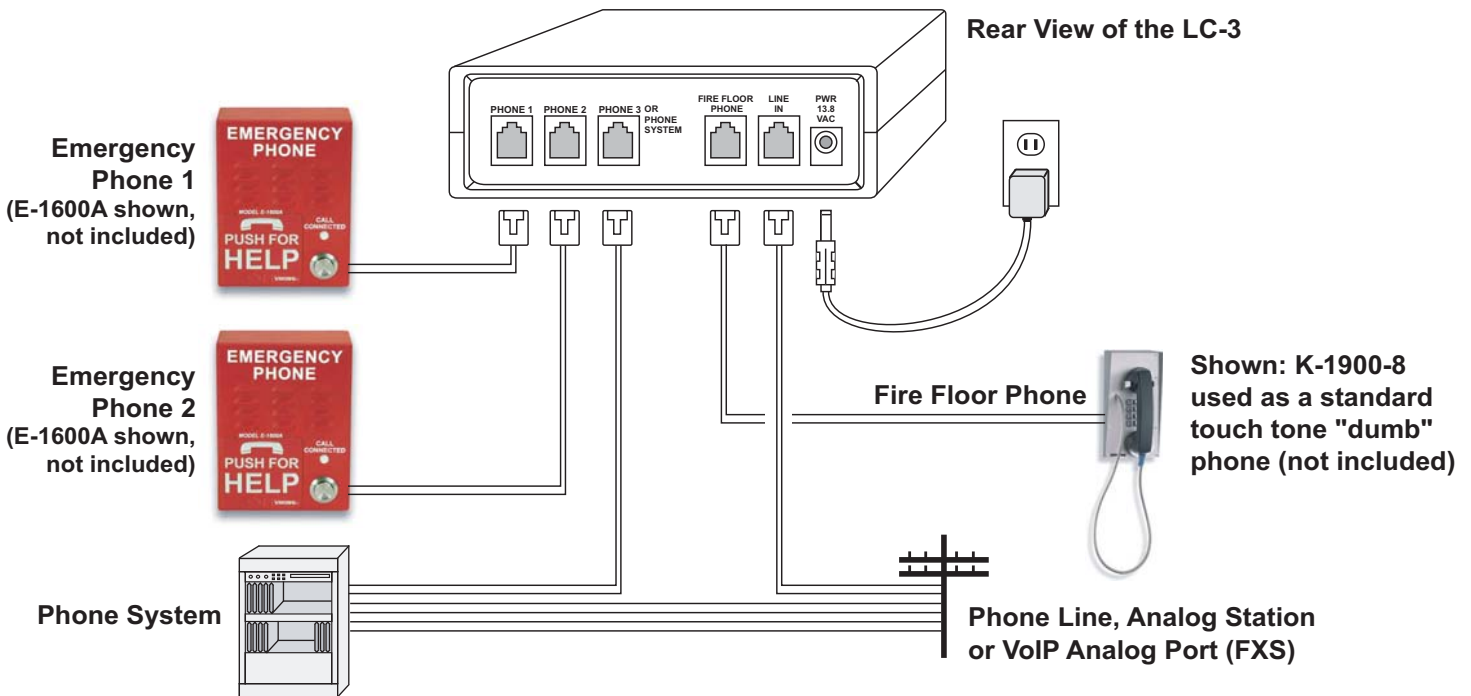

If an emergency phone comes off-hook to place an outbound call while the phone line is being used by the phone system, the phone line is removed from the phone system to simulate a hang up. After 2 second, fresh dial tone is given to the emergency phone for dialing. Because of this extra delay, it is recommended that a 4 second pause is programmed at the beginning of each emergency phone's dialing string. The phone system is given a busy signal while an emergency phone call is in place.

Inbound calls are answered immediately by the **LC-3**. In this mode, instead of giving a double-beep, the **LC-3** gives a double ringback tone to indicate it has answered. The person calling in then has 4 seconds to enter a single touch tone "1" or "2" before it gives a second double ringback tone indicating the call has been sent to the phone system. If a single touch tone is detected the **LC-3** will ring-through to that emergency phone port.

Front panel LEDs, Fire Floor Phone, Power Fail and Prank Conditions all function as normal.

**Product Support Line...715.386.8666**

**Fax Back Line...715.386.4345**

Due to the dynamic nature of the product design, the information contained in this document is subject to change without notice. Viking Electronics, and its affiliates and/or subsidiaries assume no responsibility for errors and omissions contained in this information. Revisions of this document or new editions of it may be issued to incorporate such changes.